

# Servo Drive Selection Manual



# COMPANY PROFILE

CTB Co., Ltd. was established in 2008, focusing on the field of intelligent manufacturing, providing core components such as servo motors, torque motors, motorized spindles, and professional automation servo control solutions. The company has two wholly-owned subsidiaries, Beijing CTB technology Co., Ltd. (established in 2000) and Shandong CTB Intelligent Equipment Co., Ltd. (established in 2017).

The company is a national high-tech enterprise, a national specialized and innovative "little giant" enterprise, and a listed enterprise on the New Third Board. The company has been recognized as a "National Green Factory" and a "Smart Factory" in Beijing. It is a Beijing patent demonstration unit, a Beijing enterprise technology research and development institution, and a Beijing enterprise technology center.

The company's products include a full range of industrial automation products such as AC servo motors, AC servo drives, PLC, motion controllers, core functional components such as torque motors, motorized spindles, direct drive turntables. The core technology has reached the international advanced level, and key products can replace imported similar products, widely used in CNC machine tools, industrial robots, industrial automation and other fields.

The company has core technologies with independent intellectual property rights, over 300 patents and software copyrights, including more than 30 invention patents. Its servo control system technology is at the leading level in China, and it has mastered core technologies such as servo control space vector algorithm, control software development, servo drive design, servo motor electromagnetic design, and manufacturing processes.

The company has two intelligent equipment industrial parks in Beijing and Shandong, with a business area of 100000 square meters. Advanced equipment, strict management, sufficient production capacity, and strong production and supply capabilities. There are 30 offices nationwide, with a sales and service network covering the north and south of China, providing efficient and professional pre-sales, in sales, and after-sales services for our customers.



# CONTENTS

---

D18 AC Servo Drive .....	P 03
D18-G AC Servo Drive .....	P 07
MBS Series Four Quadrant Multi Transmission AC Servo Drive .....	P 11
PCS Series Press Drive Controllers .....	P 16
ECM Series Module Accumulators .....	P 21

# D18 Series AC Servo Drive

D18 Series Servo Drives are high-performance vector servo drives with abundant industrial bus interfaces. They are used to control IM servo motors, SPM servo motors and IPM servo motors.



High matching and high responsiveness make mechanical motion more flexible.



## Abundant bus interfaces

Mechatrolink-III, EtherCAT, ProfiNet, ModbusTCP.

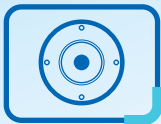

## Applicable to various encoders

Applicable to various encoder feedback signals (TTL 1VPP BISS-C ENDAT2.2 SSI RESOLVER RS485).



## High dynamic responsiveness

1 KHz speed response frequency, self-suppression of vibration, and self-learning of dynamic properties.

## Industrial Applications



## D18 Drive Model Description

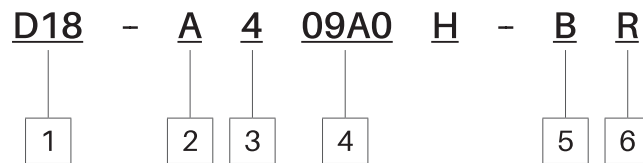

Code	Description	Instructions	Example Model
1	Product series	D18: 18 series drive	18 series drive
2	Type of product	A: I/O motherboard B: Bus motherboard G: High overload protection	I/O motherboard
3	Voltage rating	2: 200V 4: 400V 6: 600V	400 V
4	Rated current	See 'Specifications'.	9 A
5	Type of motherboard	B: I/O interface with terminals S: High density plug(CP18-S) E: EtherCAT(CP18-E) M: Mechatrolink-III(CP18-M) P: Profinet(CP18-P)	I/O interface with terminals
6	Built in braking resistor	R: Built in braking resistor	Built in braking resistor

## Overall and Mounting Dimensions of D18 Drives

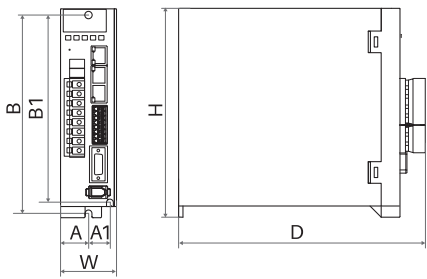

FIG. 1 (1.5~3.3A)

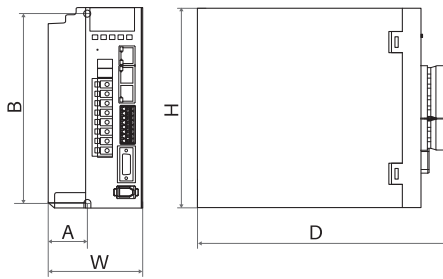

FIG. 2 (5.5~16A)

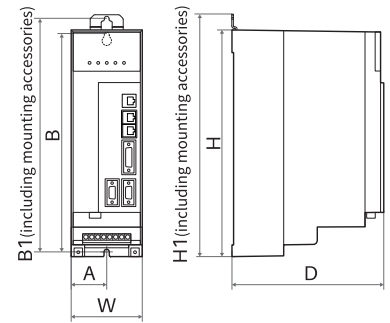

FIG. 3 (4~9A)

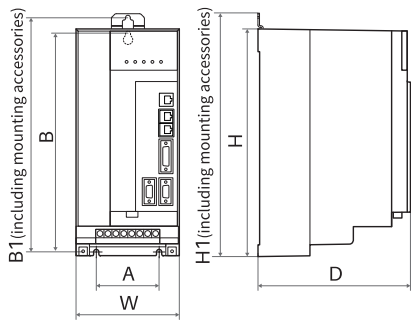

FIG. 4 (12~22A)

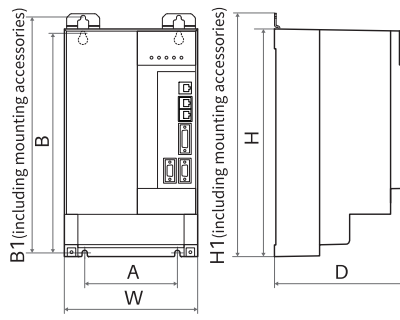

FIG. 5 (32~110A)

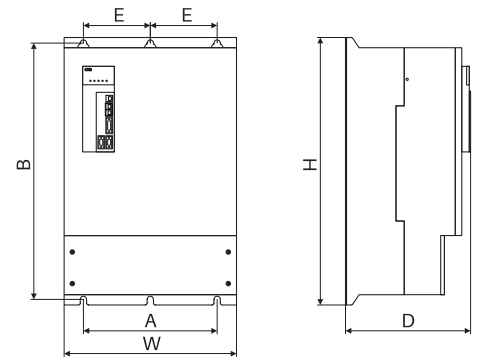

FIG. 6 (150~320A)

Dimension Model	A	A1	B	B1	W	H	H1	D	E	Terminal Screws	Mounting Screws	Weight (kg)	Remarks
D18-A(B)203A3	22.5	17.5	159.5	150.5	45	168	-	200	-	Clamp width 3mm	M5	1.5	FIG. 1
D18-A(B)209A5	31	-	150	-	75	160	-	200	-	Clamp width 3mm	M5	2.5	FIG. 2
D18-A(B)216A0													
D18-A(B)404A0	45.5	-	276	B+22	91	290	H+19	194	-	Clamp width 3mm	M6	3	FIG. 3
D18-A(B)406A0													
D18-A(B)409A0													
D18-A(B)412A0	80	-	276	B+22	132	290	H+19	194	-	Clamp width 5mm	M6	5	FIG. 4
D18-A(B)416A0													
D18-A(B)422A0	140	-	319	B+22	195	333	H+19	194	-	M6	M6	12	FIG. 5
D18-A(B)432A0													
D18-A(B)438A0													
D18-A(B)445A0	140	-	330	-	195	345	-	236	-	M6	M6	12	FIG. 5
D18-A(B)460A0													
D18-A(B)475A0	236	-	376	-	282	390	-	260	-	M8	M8	20	FIG. 5
D18-A(B)490A0													
D18-A(B)40110	300	-	376	-	380	390	-	260	-	M8	M8	26	FIG. 6
D18-A(B)40150													
D18-A(B)40180													
D18-A(B)40220	392	-	376	-	472	390	-	260	196	M10	M8	33	FIG. 6
D18-A(B)40280													
D18-A(B)40320													
D18-A(B)40220	360	-	690	-	464	720	-	335	180	M10	M10	90	FIG. 6
D18-A(B)40280													
D18-A(B)40320													

## Standard Specifications and Performance Data

D18-BXXXXX		203A3	209A5	216A0	404A0	406A0	409A0	412A0	416A0	422A0	432A0	438A0	
Current (A)		3.3	9.5	16	4	6	9	12	16	22	32	38	
Power(kW)		0.4	1.1	2	1.5	2.2	3.7	5.5	7.5	11	15	18	
D18-BXXXX		445A0	460A0	475A0	490A0	40110	40150	40180	40220	40280	40320		
Current (A)		45	60	75	90	110	150	180	220	280	320		
Power (kW)		22	30	37	45	55	75	90	110	132	160		
Output	Max. output voltage (V)	Three-phase 200/220/240/260 V input voltage						Three-phase 380/400/415/440 V input voltage					
	Max. output speed (rpm)	4-pole motor 32000 rpm, 1,600 Hz											
Power supply	Rated voltage, frequency	Three-phase 200/220/240/260 V; 50/60 Hz						Three-phase 380/400/415/440 V; 50/60 Hz					
	Voltage fluctuation	+10%, -15%											
	Frequency fluctuation	±5%											
Control features	Mode of control	Sinusoidal wave PWM, closed loop vector control											
	Max. speed range	1:15000											
	Speed control accuracy	±0.1%											
	Frequency setting resolution	Digital: 0.01 Hz; analog: double-polarity max. output frequency/2046											
	Position control accuracy	±1 pulse											
	Acceleration/deceleration	0-3000 s											
	Brake	Dynamic braking, 125% rated torque; built-in braking unit											
Overload capacity	30 s at 200% rated current												
I/O interfaces	Digital input	Up to 14 optocoupler isolated inputs, input methods: PNP, NPN optional											
	Digital output	Up to 6 optocoupler isolated outputs, 24V, 10mA											
	Analog input	3 routes: 1 route: -10~10V 1 route: 0~10V1 Route: 0~10V or 4~20mA											
	Relay output	1×: one set of NO contacts; 250 VAC/30 VDC, 1 A											
	Fault output relay	1×: one set of NO/NC contacts; 250 VAC/30 VDC, 1 A											
	Encoder input interface	2×: motor encoder, incremental encoder, absolute encoder, intelligent encoder, external encoder											
	Pulse input	1×: directed pulse, orthogonal pulse (optional)											
	Encoder output interface	1×: 300 KHz max. output frequency, linear driverive output mode, RS422 standard											
	Bus interface	EtherCAT、Profinet、Machatrolink-III、RS485											
Controls	Speed control	Range: 0-32000 rpm; direction: CW, CCW; speed commands: analog, pulse frequency, multi-stage speed control, communication											
	Position control	Auto zero return, reciprocating positioning, multi-point positioning											
	Torque control	Reeling control, swing control, torque control											
	Others	External encoder positioning, synchronous drive, hydraulic servo, PID control											
Protection	Drive/motor over-current	Independent detection of drive and motor over-current											
	Drive/motor overload	Independent detection of drive and motor overload											
	Motor overheat	Built-in motor overheat interface											
	Low voltage/over-voltage	Main circuit busbar voltage: over-voltage alarm output if higher than 800 V; under-voltage alarm output if lower than 400 V											
Working environment	Working site	No dust, corrosive gases or combustible gases											
	Temperature	-10 to 45 °C											
	Humidity	<95%RH (non-condensing)											
	Vibration	Vibration frequency ≤20 Hz: 9.8 m/s <sup>2</sup> ; 20 Hz ≤vibration frequency ≤50 Hz: 2 m/s <sup>2</sup>											

# D18-G Series AC Servo Drives

D18-G series servo drives are the latest high-performance medium to highpower AC servo products developed by CTB. D18-G series servo drives have notonly excellent performance and ease of use of GH series, but the configuration and design are optimized for the severe and much powder working conditions of the press industry. The power ranges from 22kW to 450 kW. Combined with related communication interfaces and the host,it can realize joint operation of multiple servo drives.



## Product Features

- 1、High IP rating: Overall IP rating of IP40, suitable for working conditions with much powder.
- 2、Excellent control: integrates position, speed, and torque control, supporting IM motors, SPM motors, and IPM motors.
- 3、High overload rating: Up to 2 times or more overload capacity.
- 4、Accurate control algorithm: Improve equipment process and processing efficiency.
- 5、Multiple modes of bus communication : supports bus communication such as Modbus TCP, EtherCat, Profinet, Mechatrolink III.
- 6、Strong compatibility: TTL、1VPP、BISS-C、ENDT2.2、SSI、RESOLVER、RS485.

## Industrial Applications



## D18-G Drive Model Description

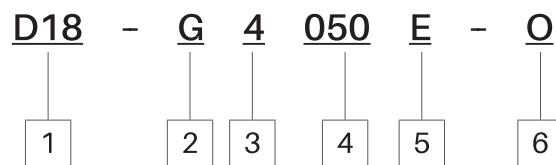

Code	Description	Instructions	Example Model
1	Product series	Code of the servo drive series	D18 Series servo drive
2	Code of industry	G : High overload, high protection	High overload, high protection
3	Voltage rating	2: 200V      4: 400V      6: 600V	400V
4	Rated current	See 'Specifications'.	Rated current: 50 A
5	Type of product	T: I/O plug type: (pulse sequence, RS485 standard modbus) M3: Mechatrolink III communication type ET: EtherCat bus PN: Profinet bus	EtherCAT bus
6	Export marking	Domestic product: NONE      Export product: Letter 'O'	Export product

## Overall and Mounting Dimensions of D18-G Drives

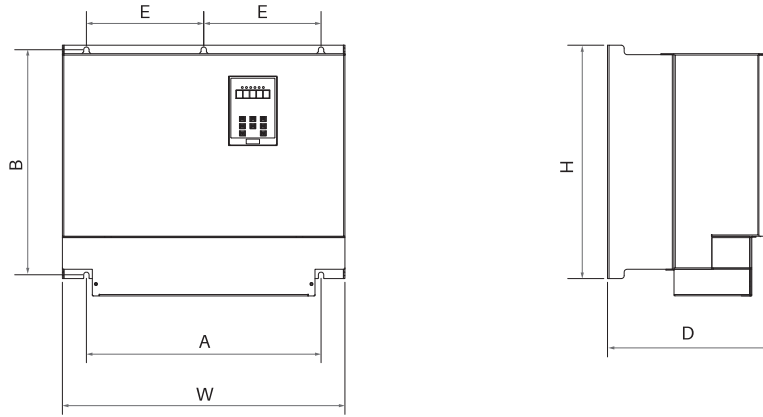

FIG. 1

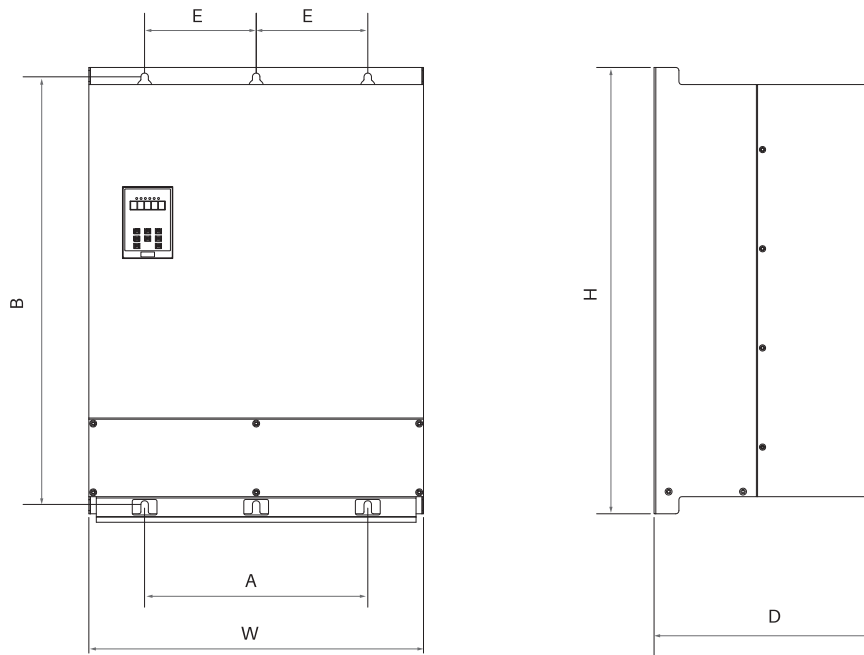

FIG. 2

Model \ Dimension	A	B	W	H	D	E	Terminal Screws	Mounting Screws	Weight (kg)	Remarks
D18-G4050	250	376	282	390	270	-	M8	M8	20	FIG. 1
D18-G4075										
D18-G4090	340	376	380	390	270	-	M8	M8	26	
D18-G4120										
D18-G4150	392	376	472	390	270	196	M10	M8	33	
D18-G4220										
D18-G4320	360	690	540	720	380	180	M12	M10	90	FIG. 2
D18-G4450										
D18-G4600	500	1165	720	1200	435	250	M12	M16	130	
D18-G4750										

## Standard Specifications and Performance Data

Model:D18-G4XXX		4050	4075	4090	4120	4150	4220	4320	4450	4600	4750
Rated current (A)		50	75	90	120	150	220	320	450	600	750
Max. current (A)		80	120	180	240	300	360	500	700	900	1200
Output	Max. output voltage (V)	Three-phase 200/220/240/260 V input voltage					Three-phase 380/400/415/440 V input voltage				
	Max. output speed	4-pole motor: 32,000 rpm, 1,600 Hz									
Power supply	Rated voltage, frequency	Three-phase 200/220/240/260 V; 50/60 Hz					Three-phase 380/400/415/440 V; 50/60 Hz				
	Voltage fluctuation	+10% , -15%									
	Frequency fluctuation	±5%									
Control features	Mode of control	Sinusoidal wave PWM, closed loop vector control									
	Max. speed range	1: 15000									
	Speed control accuracy	±0.1%									
	Frequency setting resolution	Digital: 0.01 Hz; analog: double-polarity max. output frequency/2046									
	Position control accuracy	±1 PULSE									
	Acceleration/deceleration	0 ~ 3000s									
	Brake	Dynamic braking, 125% rated torque; built-in braking unit									
	Overload capacity	30 s at 200% rated current									
I/O interfaces	Digital input	Up to 14 optocoupler isolated inputs, input methods: PNP, NPN optional									
	Digital output	Up to 6 optocoupler isolated outputs, 24V, 10mA									
	Analog input	3 routes: 1 route: -10~10V 1 route: 0~10V1 Route: 0~10V or 4~20mA									
	Relay output	1×: one set of NO contacts; 125 VAC/30 VDC, 1 A									
	Fault output relay	1×: one set of NO/NC contacts; 125 VAC/30 VDC, 1 A									
	Encoder input interface	2×: incremental encoder, intelligent encoder									
	Pulse input	1×: directed pulse, orthogonal pulse (optional)									
	Encoder output interface	1×: 300 KHz max. output frequency, linear driverive output mode, RS422 standard									
	Bus interface	EtherCAT、ProfiNet、Mechatrolink III、RS485									
Controls	Speed control	Range: 0-32000 rpm; direction: CW, CCW; speed commands: analog, pulse frequency, multi-stage speed control, communication									
	Position control	Auto zero return, reciprocating positioning, multi-point positioning									
	Torque control	Reeling control, swing control, torque control									
	Others	External encoder positioning, synchronous drive, hydraulic servo, PID control									
Protection	Drive/motor over-current	Independent detection of drive and motor over-current									
	Drive/motor overload	Independent detection of drive and motor overload									
	Motor overheat	Built-in motor overheat interface									
	Low voltage/over-voltage	Main circuit busbar voltage: over-voltage alarm output if higher than 800 V; under-voltage alarm output if lower than 400 V									
Working environment	Working site	No dust, corrosive gases or combustible gases									
	Temperature	-10 ~ 45°C									
	Humidity	<95%RH (non-condensing)									
	Vibration	Vibration frequency ≤20 Hz: 9.8 m/s <sup>2</sup> ; 20 Hz ≤vibration frequency ≤50 Hz: 2 m/s <sup>2</sup>									

# MBS Series Four Quadrant Multi Transmission AC Servo Drive

The MBS series four quadrant multi transmission AC servo drive is a high-quality, multifunctional, and low-noise AC servo drive developed and produced by CTB Co., Ltd. The MBS series AC servo drive can conveniently control the position, speed, acceleration, and output torque of various AC servo motors.

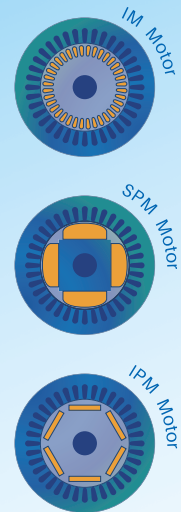

## Product Features

- 1、 Equipped with dual 32-bit CPUs and rich control function modules, it can achieve control functions for various machine tools.
- 2、 The standard control interface can be easily connected to various CNC systems at home and abroad, allowing the functions of the CNC system to be fully utilized.
- 3、 Machine tools equipped with MBS series AC servo drives will exhibit extraordinary torque characteristics, acceleration and deceleration characteristics, accuracy characteristics, and efficiency characteristics, and can easily achieve functions such as accurate stop, C-axis, rigid tapping, electronic shifting, and multi axis synchronization.

## Industrial Applications



## MBS Drive Model Description

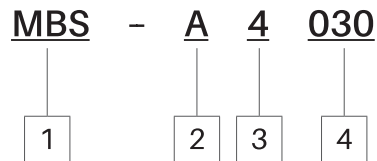

Code	Description	Instructions	Example Model
1	Product series	<b>MBS:</b> MBS series drive	MBS series drive
2	Type of product	<b>A:</b> Rectifying unit (Power module)	Rectifying unit (Power module)
3	Voltage rating	<b>4:</b> 400V <b>6:</b> 600V	400V
4	Power code	See 'Specifications'.	30KW

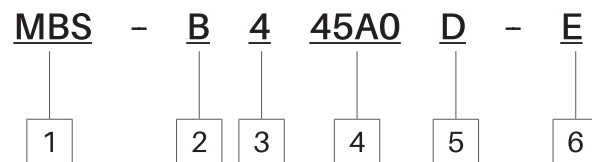

Code	Description	Instructions	Example Model
1	Product series	<b>MBS:</b> MBS series drive	MBS series drive
2	Type of product	<b>B:</b> Inverter unit (Driver module)	Inverter unit (Driver module)
3	Voltage rating	<b>4:</b> 400V <b>6:</b> 600V	400V
4	Rated current	See 'Specifications'.	45A
5	number of axes	<b>D:</b> 2 axes <b>S:</b> 1 axes	2 axes
6	Type of motherboard	<b>E:</b> EtherCAT <b>P:</b> ProfiNet	EtherCAT

## Overall and Mounting Dimensions of MBS Drives

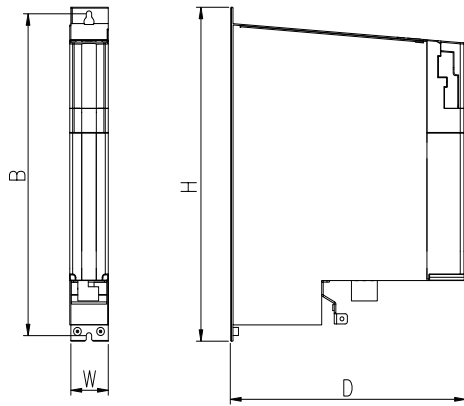

FIG. 1

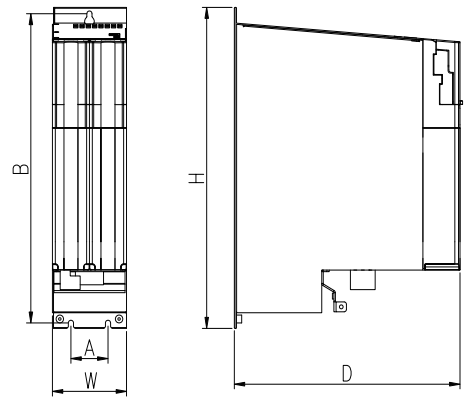

FIG. 2

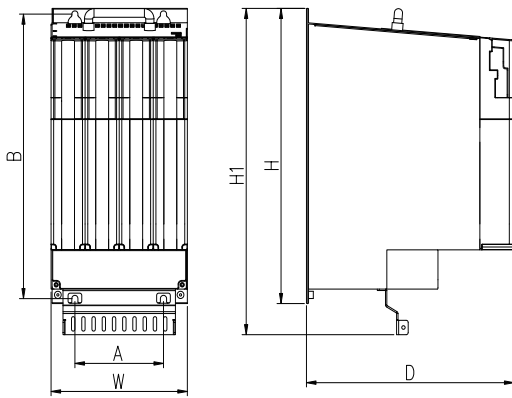

FIG. 3

	Model	Dimension	A	B	W	H	D	H1	Terminal Screws	Mounting Screws	Weight (kg)	Remarks
Inverter unit	MBS-B404A0	—	395	50	410	305	—	—	Clamp width 3mm	M6	6.2	FIG.1
	MBS-B406A0											
	MBS-B409A0											
	MBS-B412A0	50	395	100	410	305	-	-	Clamp width 5mm	M6	8.8	FIG.2
	MBS-B416A0											
	MBS-B422A0											
	MBS-B432A0											
	MBS-B438A0	100	395	150	410	305	455	M8	M6	10	FIG.3	
	MBS-B445A0											
	MBS-B460A0	130	395	200	410	305	455	M8	M8	10.3		
	MBS-B475A0											
	MBS-B490A0	200	395	300	410	305	455	M10	M8	19.5		
MBS-B40110												
MBS-B40150												
Rectifying unit	MBS-A4030	100	395	150	410	305	455	M8	M6	10		
	MBS-A4045	130	395	200	410	305	455	M8	M8	10.3		
	MBS-A4090	200	395	300	410	305	455	M10	M8	19.5		

## Rectifying unit Standard Specifications and Performance Data

MBS-AXXXXX		A4030	A4045	A4090
Current (A)		60	90	180
power (Kw)		30	45	90
Max.Current (A)		120	200	360
Power supply	Rated voltage, frequency	Three-phase 400/600V; 50/60Hz		
	Voltage fluctuation	±15%		
	Frequency fluctuation	±3%		
Control features	Mode of control	120° PWM		
	Max. overload time	1.5 times rated current for 1min		
I/O interfaces	Digital input	4 optocoupler isolated inputs, input methods: PNP, NPN optional		
	Digital output	1 optocoupler isolated outputs, 24V, 10mA		
	Fault output relay	1×: one set of NO contacts; AC250V/DC30V, 1A		
	Bus interface	RS485		
Feedback method	Automatic feedback method	Determine whether to provide feedback based on the feedback voltage threshold set by the user		
	Manual feedback method	After providing Enable, Always in a feedback state		
Protection	Drive over-current	Independent detection of drive over-current		
	Drive overload	Independent detection of drive overload		
	Low voltage/over-voltage	Main circuit busbar voltage: over-voltage alarm output if higher than 800 V; under-voltage alarm output if lower than 400 V		
Working environment	Working site	No dust, corrosive gases or combustible gases		
	Temperature	-10 to 45 °C		
	Humidity	<95%RH (non-condensing)		
	Vibration	Vibration frequency ≤20 Hz: 9.8 m/s <sup>2</sup> ; 20 Hz ≤vibration frequency ≤50 Hz: 2 m/s <sup>2</sup>		

## Inverter unit Standard Specifications and Performance Data

MBS-BXXXXX		B404A0	B406A0	B409A0	B412A0	B416A0	B422A0	B432A0
Current (A)		4	6	9	12	16	22	32
Capacity (KVA)		1.5	2.2	3.7	5.5	7.5	11	15
MBS-BXXXX		B438A0	B445A0	B460A0	B475A0	B490A0	B40110	B40150
Current (A)		38	45	60	75	90	110	150
Capacity (KVA)		18	22	30	37	45	55	75
Output	Max. output voltage (V)	Three-phase 200/220/240/260 V input voltage			Three-phase 380/400/415/440 V input voltage			
	Max. output speed (rpm)	4-pole motor 32000 rpm, 1,600 Hz						
Power supply	Rated voltage, frequency	Three-phase 200/220/240/260 V; 50/60 Hz			Three-phase 380/400/415/440 V; 50/60 Hz			
	Voltage fluctuation	+ 10% , - 15%						
	Frequency fluctuation	±5%						
Control features	Mode of control	Sinusoidal wave PWM, closed loop vector control						
	Max. speed range	1: 15000						
	Speed control accuracy	±0.1%						
	Frequency setting resolution	Digital: 0.01 Hz						
	Position control accuracy	±1 PULSE						
	Acceleration/ deceleration	0 ~ 3000s						
	Brake	Dynamic braking, 125% rated torque; built-in braking unit						
	Overload capacity	30 s at 200% rated current						
I/O interfaces	Digital input	4 optocoupler isolated inputs, input methods: PNP, NPN optional						
	Digital output	1 optocoupler isolated outputs, 24V, 10mA						
	Fault output relay	1×: one set of NO/NC contacts; 250 VAC/30 VDC, 1 A						
	Encoder input interface	2×: motor encoder, incremental encoder, absolute encoder, intelligent encoder, external encoder						
	Pulse input	1×: directed pulse, orthogonal pulse (optional)						
	Bus interface	EtherCAT、ProfNet、Machatrolink-III、RS485						
Controls	Speed control	Range: 0-32000 rpm; direction: CW, CCW; speed commands: analog, pulse frequency, multi-stage speed control, communication						
	Position control	Auto zero return, reciprocating positioning, multi-point positioning						
	Torque control	Reeling control, swing control, torque control						
	Others	External encoder positioning, synchronous drive, hydraulic servo, PID control						
Protection	Drive/motor over-current	Independent detection of drive and motor over-current						
	Drive/motor overload	Independent detection of drive and motor overload						
	Motor overheat	Built-in motor overheat interface						
	Low voltage/over-voltage	Main circuit busbar voltage: over-voltage alarm output if higher than 800 V; under-voltage alarm output if lower than 400 V						
Working environment	Working site	No dust, corrosive gases or combustible gases						
	Temperature	- 10 ~ 45°C						
	Humidity	<95%RH (non-condensing)						
	Vibration	Vibration frequency ≤20 Hz: 9.8 m/s <sup>2</sup> ; 20 Hz ≤vibration frequency ≤50 Hz: 2 m/s <sup>2</sup>						

# PCS Series Press Drive Controllers

The PCS series drive control integrated cabinet is a new integrated cabinet product specially developed for servo presses. It integrates control and drive, and can achieve motion control of the entire servo press and high-performance vector control of HPM series permanent magnet synchronous motors and YH series slider motors. According to the tonnage of the press, it can be flexibly combined (single cabinet, multiple cabinets). The integrated cabinet integrates various electrical peripherals in a three-dimensional manner, making it easy for customers to deliver and apply in an integrated manner.



## Product Features

1. Control circuit: Integrated high-performance motion controller, including all curve processes of servo press, connected to the main driver and slider driver through bus communication. Equipped with an energy management system, it fully considers electromagnetic interference issues while saving space.
2. Drive circuit: adopting high-performance vector control technology, low-speed high torque output, with good dynamic characteristics and super overload capacity. The main drive device and slider drive device have user background software monitoring, Profinet, EtherCAT communication bus functions optional, supporting multiple encoder types, rich and powerful combination functions, and stable performance. Equipped with emergency braking circuit and quick discharge circuit as standard. At the same time, it is equipped with an ECO energy-saving mode to achieve the best energy-saving effect.

## Industrial Applications



## PCS10 Drive Model Description

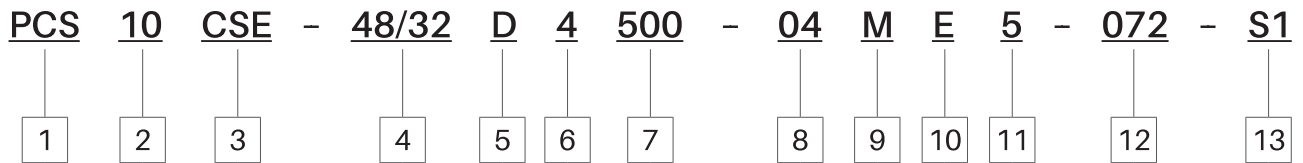

Code	Description	Instructions	Example Model
1	Product series	PCS: code of cabinet type products for the press industry	Press controller
2	Type of cabinet	10: Drive controller (size: 2100×900×650, double door)	10
3	Type of product	C: Control unit S: Drive unit E: Energy storage unit	Control unit +Drive unit+Energy storage unit
4	I/O quantity	48: 8-point digital input *6 32: 8-point digital input *4	48-point digital input /32-point digital input
5	Type of motherboard	C: CP18G-IO D: CP18G	CP18G
6	Voltage rating	4: AC 3PH 380V 6: AC 3PH 695V	400V
7	Peak current	180A 240A 270A 360A 500A	Peak current: 500A
8	Slider Servo drive	03: Rated current3A 08: Rated current8A 13: Rated current13A NONE : NONE	Rated current4A
9	Smart card	M: MEZ2M Smart card NONE : NONE	MEZ2M Smart card
10	Bus type	T: I/O plug type: (pulse sequence, RS485 standard modbus) M3: Mechatrolink III communication type ET: EtherCat bus PN: Profinet bus	EtherCAT bus
11	Encoder	5: The signal mode of the main motor encoder is smart car	Smart card
12	Energy storage unit	072: Capacity 72mF 216: Capacity 216mF	Capacity 72mF
13	Star sealing	S1: Single motor S2: Double motors	Single motor

## PCS20 Drive Model Description

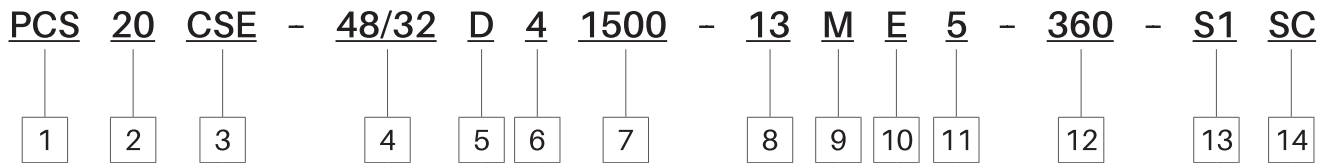

Code	Description	Instructions	Example Model
1	Product series	PCS: code of cabinet type products for the press industry	Press controller
2	Type of cabinet	20: combinatorial: Control unit +Drive unit+Energy storage unit (control unit size: 2100*900*650, double door) (drive unit size: 2100*1000*650, double door)	20
3	Type of product	C: Control unit S: Drive unit E: Energy storage unit	Control unit +Drive unit+Energy storage unit
4	I/O quantity	48: 8-point digital input *6 32: 8-point digital input *4	48-point digital input /32-point digital input
5	Type of motherboard	C: CP18G-IO D: CP18G	CP18G
6	Voltage rating	4: AC 3PH 380V 6: AC 3PH 695V	400V
7	Peak current	1 drive unit: 700A、900A、1200A、1500A 2 drive unit: 1800A、2400A、3000A	Peak current 1500A (drive unit)
8	Slider Servo Drive	03: Rated current3A 08: Rated current8A 13: Rated current13A NONE : NONE	Rated current 13A
9	Smart card	M: MEZ2M Smart card None: None	MEZ2M Smart card
10	Bus type	T: I/O plug type: (pulse sequence, RS485 standard modbus) M3: Mechatrolink III communication type ET: EtherCAT bus PN: Profinet bus	EtherCAT bus
11	Encoder	5: The signal mode of the main motor encoder is smart card	Smart card
12	Energy storage unit	072: Capacity 72mF 216: Capacity 216mF 288: Capacity 288mF 360: Capacity 360mF	Capacity 360mF
13	Star sealing	S1: Single motor S2: Double motors	Single motor
14	Synchronization function	SC: Dual drive synchronization function None: No dual drive synchronization function	Dual drive synchronization function

## Overall and Mounting Dimensions

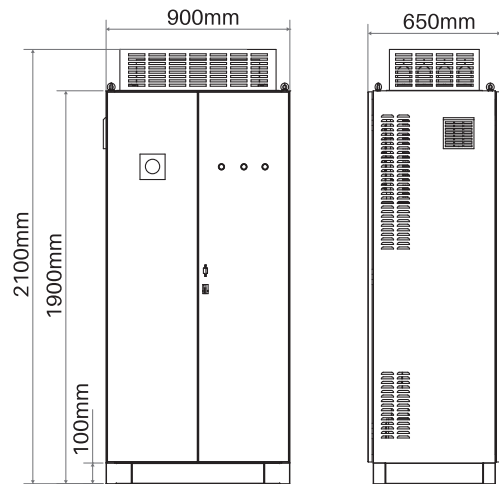

Configuration list for servo press machines with tonnage of 200 tons and below

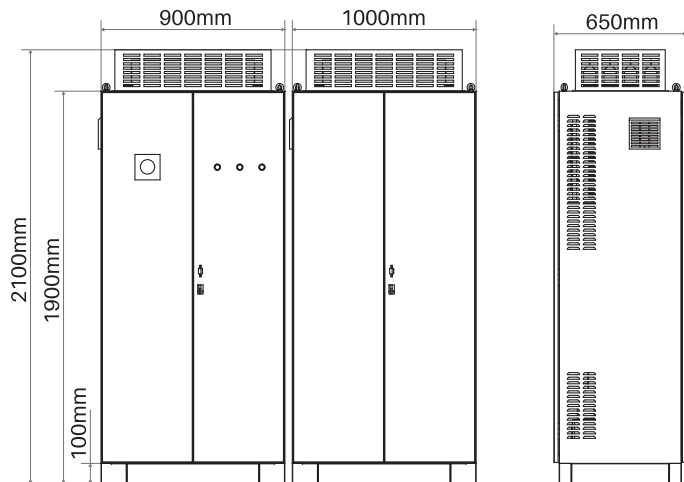

Configuration list for servo press machines with tonnage of 200 tons and more than

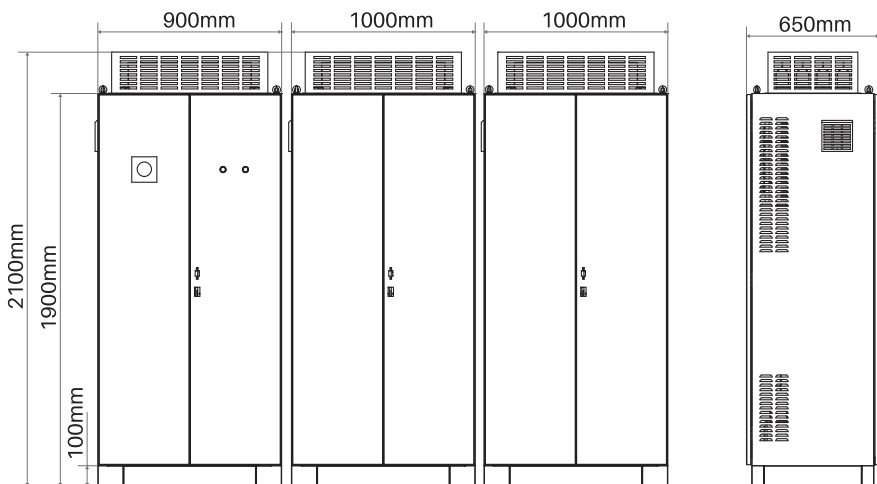

Configuration list for Double Servo Motor Press Machine

## Inverter unit Standard Specifications and Performance Data

Model		200/300	400/600	600/900	800/1200	1000/1500
Motor capacity (kW)		100	200	300	400	500
Output	Capacity (KVA)	100	200	300	400	500
	Max. current (A)	300	600	900	1200	1500
	Max. output voltage (V)	Three-phase 380/440 V input voltage				
	Max. output speed (rpm)	4-pole motor: 32,000 rpm, 1,600 Hz				
Power supply	Rated voltage, frequency	Three-phase 380/440 V; 50/60 Hz				
	Voltage fluctuation	10%				
	Frequency fluctuation	5%				
Control features	Mode of control	Closed loop control of speed/position and torque				
	Torque properties	200% rated torque output below basic frequency; accuracy: $\pm 5\%$				
	Max. speed range	1:15,000				
	Speed control accuracy	$\pm 0.1\%$				
	Frequency setting resolution	Digital: 0.01 Hz; analog: single-polarity, max. output frequency/4092; dual-polarity, max. output frequency/2046				
	Position control accuracy	$\pm 1$ pulse				
	Acceleration/deceleration	0-3,000 s				
	Brake	Dynamic braking, 125% rated torque; built-in braking unit				
	Overload capacity	30 s at 200% rated current				
I/O interfaces	Digital input	2 Motor encoders, capable of receiving incremental encoder, resolver, sine cosine encoder, absolute encoder, intelligent encoder, external encoder				
	Digital output	1 Maximum output frequency 300KHz, line drive output mode, RS422 standard				
	Bus interface	EtherCat, ProfiNet				
Controls	Debugging mode (manual function)	used for debugging and adjusting the mechanical position in manual mode ① Slider jog up: Through this function, the slider jog up is achieved ② Slider jog lowering: Through this function, the slider jog lowering is achieved				
	Automatic mode	according to the set crankshaft mode, pressure maintaining mode, connecting rod mode, pendulum mode, etc; Free mode can preset various stamping curves and other production process requirements for safe operation stamping and continuous stamping				
	Protection function	a logical protection function designed to ensure the safety of personnel and equipment				
	Monitoring display	① Real time display of motor current, crankshaft angle, slider displacement, etc ② Real time display of alarm information ③ Real time display of IO status				
	Hand wheel function	By operating the hand wheel, the slider can be moved slightly				
Protection	Drive/motor over-current	Independent over-current detection of drive and motor				
	Drive/motor overload	Independent overload detection of drive and motor				
	Motor overheat	Built-in motor overheat interface				
	Low voltage/over-voltage	Main circuit busbar voltage: over-voltage alarm output if higher than 800 V; under-voltage alarm output if lower than 400 V				
Working environment	Working site	No dust, corrosive gases or combustible gases				
	Temperature	-10 to 45 °C				
	Humidity	<95%RH (non-condensing)				
	Vibration	Vibration frequency $\leq 20$ Hz: 9.8 m/s <sup>2</sup> ; 20 Hz $\leq$ vibration frequency $\leq 50$ Hz: 2 m/s <sup>2</sup>				

# ECM Series Module Accumulators

The ECM series module energy storage device is a new type of energy storage device that comes with an RS485 communication interface. Combined with a super synchronous upper computer control system, it can achieve energy-saving data transmission and facilitate intuitive understanding of energy-saving effects. As an efficient energy storage device, it is widely used in important fields and links such as national defense and military industry, rail transportation, and potential energy recovery of lifting machinery.

Input voltage: 350-800 VDC

Spec.: 20 mF, 32 mF, 72 mF

## Product Features

- Short charging time
- Long life
- Good temperature properties
- Easy wiring
- Stable & reliable
- Green & environmental



## Overall dimensions

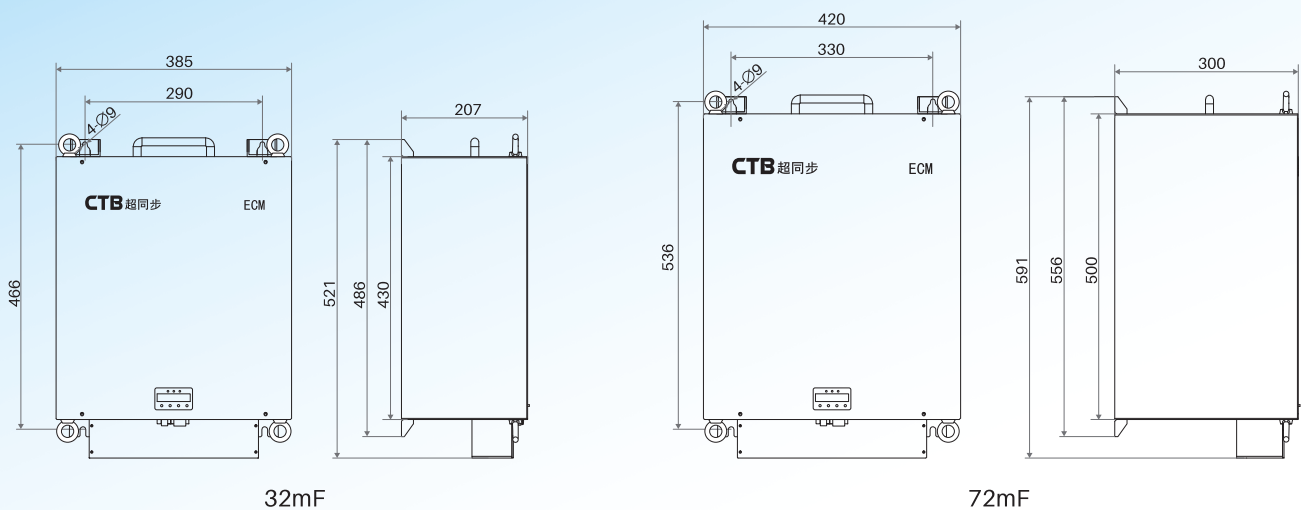

## Industrial Applications



# Configuration of Resistor and Resistance Box

D18-XXXX		04A0	06A0	09A0	12A0	16A0	22A0	32A0	38A0	45A0	60A0	75A0	90A0	0110	0150	0180	0220	0280	0320	
Brake resistor	Power (W)	200	300	800	1500	1500	1500	1500	2000	2000	2000	2000	2500	2500	2500	2500	2500	2500	2500	
	Resistance (Ω)	150	100	40	40	30	40	40	40	40	40	32	32	55	55	55	55	55	55	
	Quantity	1	1	1	1	1	2	2	2	2	2	2	2	4	4	4	4	6	8	8
	Type	Ripple resistor or Al housed resistor											Ripple resistor							
Resistance box		None											884×400×155				884×400×294			

Brake Resistor Overall and Mounting Dimensions

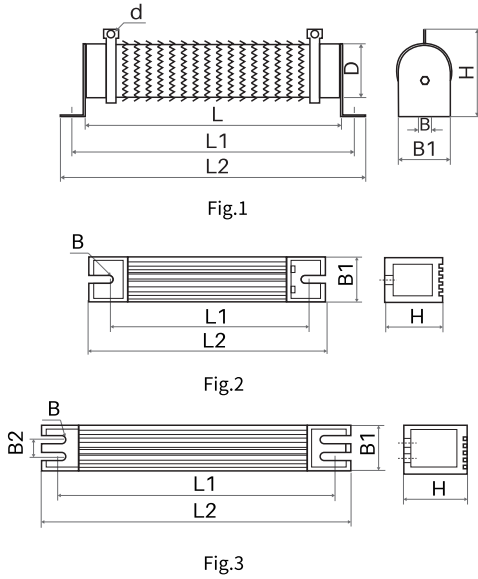

Resistance Box Overall and Mounting Dimensions

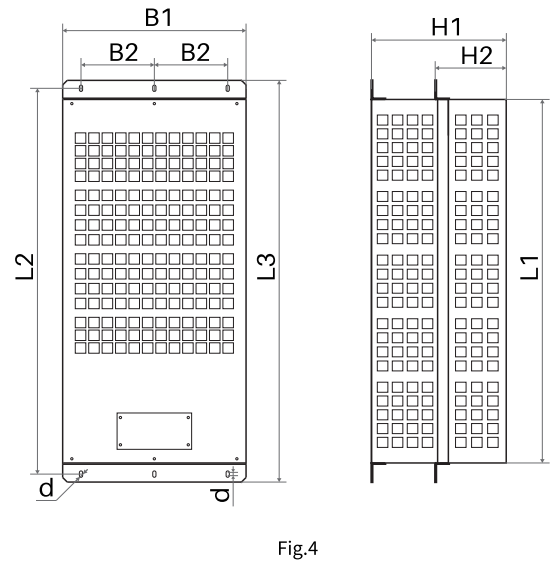

Resistor Model	Power (W)	Resistance (Ω)	Dimensions (mm)								Incoming Line Hole DIA	Remarks
			L	L1	L2	B	B1	B2	H	d		
B200W/150R	200	150	197	219	241	8	40	/	87.3	5.5	Fig.1	
B300W/100R	300	100	284	306	328	8	40	/	81	5.5		
B800W/40R	800	40	324	346	368	8	50	/	99	6.5		
B1500W/30R	1500	30	414	439	464	8.5	60	/	119	6.5		
B1500W/40R	1500	40	414	439	464	8.5	60	/	119	6.5		
B2000W/32R	2000	32	509	534	559	8.5	60	/	119	6.5		
B2000W/40R	2000	40	509	534	559	8.5	60	/	119	6.5		
B2500W/55R	2500	55	599	624	649	8.5	60	/	119	6.5		
L200W/150R	200	150	/	153	171	5.5	60	/	30	5.2		Fig.2
L300W/100R	300	100	/	203	221	5.5	60	/	30	5.2		
L800W/40R	800	40	/	388	406	5.5	61	/	59	5.2		
L1500W/30R	1500	30	/	469	485	5.5	50	30	107	6	Fig.3	
L1500W/40R	1500	40	/	469	485	5.5	50	30	107	6		
L2000W/40R	2000	40	/	536	550	5.2	100	80	50	6		
L2000W/32R	2000	32	/	536	550	5.2	100	80	50	6		

Resistance Box Model	Max. No. of Resistors	Dimensions (mm)							Incoming Line Hole DIA	Remarks
		L <sub>1</sub>	L <sub>2</sub>	L <sub>3</sub>	B <sub>1</sub>	B <sub>2</sub>	H <sub>1</sub>	H <sub>2</sub>		
884×400×155	4	800	849	884	400	160	/	155	7	Fig.4
884×400×294	8	800	849	884	400	160	295	/	7	

STRIVE FOR CONTINUAL SELF-RENEWAL KEEP PACE WITH THE WORLD



Professional manufacturer of mechatronics products

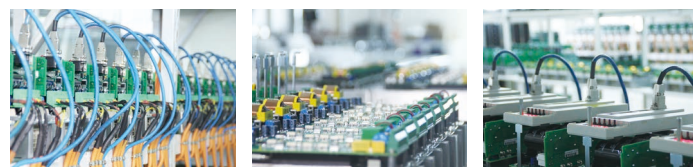

Address: No. 9, 6th Yunxi Road, Miyun Economic Development  
Zone, Beijing (101500)  
Tel: 010-69076533  
Fax: 010-69076577  
<http://www.ctb.com.cn>  
24 h national toll-free service line: 400-888-9055



WeChat



Tiktok

Due to constant technological improvements, texts, drawings and technical data in the manual may be changed without prior notice.