

INSTRUCTION MANUAL FOR LATHE MOTORIZED SPINDLE

PLEASE GIVE THESE OPERATING INSTRUCTIONS TO THE END
USER AND KEEP THEM PROPERLY.



★ Special Precautions ★



Note

Please be sure to contact a CTB technical service engineer for pre-startup training and guidance before the power-up.



Note: Spindle Running-in

★Precautions:

The spindle must be run-in (refer to item 2.2 on page 17 of the manual for the run-in method) after being powered on for the first time or after a long period of non-operation.

★Precautions:

Monitor the bearing temperature during the running-in period; if it exceeds 60°C, stop the operation and wait until the temperature drops before continuing; if the temperature of the spindle still cannot reach an even temperature or if there are abnormal noises after repeated running-in periods, please contact our technical service engineer.



Note: Locking Logic

★Precautions:

The logic of the spindle locking function must be correct (refer to item 3.3 on page 22 of the manual for the logic method).

★Precautions:

Make sure that the hydraulic pressure value meets the requirements (5 ± 0.5 Mpa) when using the spindle locking function. If the requirements cannot be met on site, shut down the machine immediately and contact technical service personnel from CTB.

★Precautions:

Do not make the hydraulic connection too long, use a flexible hose connection instead.

★Precautions:

Make sure that the inlet of the spindle locking pressure is in a pressure-free state (the value is 0) before rotating the spindle.



Note: Test Run

★Precautions:

Perform a test run of the spindle (refer to item 2.3 on page 18 of the manual for the test method).

★Precautions:

If the spindle does not operate as required, remove the relevant supporting parts. After ensuring that the spindle is in its default state, rotate the spindle to verify that it meets the requirements.

Contents

I.Precautions	1
1.Requirements for use.....	1
2.Safety instructions.....	1
3.Safe transport.....	1
4.Safe assembly and repair.....	1
5.Safety checks.....	2
6.Safe operation.....	2
7.Storage.....	2
8.Copyright.....	2
II.Introduction to Precision Lathe Motorized Spindle	3
1.Model description.....	3
2.Product description.....	4
2.1 Motor unit.....	4
2.2 Spindle specifications.....	4
2.3 Encoder.....	5
2.4 Motor cooling system.....	5
2.5 Motor thermal protection system.....	5
2.6 Bearings and lubrication.....	7
2.7 Standards for inspections.....	7
2.8 Check bar production.....	10
III.Use of the Lathe Motorized Spindle	11
1.Spindle installation.....	11
1.1 Cleaning the spindle and related parts.....	11
1.2 Checking the accuracy of the spindle and related parts.....	11
1.3 Spindle installation.....	14
1.4 Electrical connection	15
2.Motorized spindle trial run.....	17
2.1 Pre-operation check.....	17
2.2 Operation.....	17
2.3 Operation check.....	18
3.Installation and application of accessories.....	19
3.1 Connecting the chuck cylinder	19
3.2 Cooling the motorized spindle.....	21
3.3 Spindle braking.....	22
3.4 Critical Operating Statement.....	22
IV.Troubleshooting	23

I. Precautions

1. Requirements for use (Important!!)

The Lathe Motorized Spindle is a main driver component specially designed for use on CNC lathes. It can be connected to a rotary cylinder for use with a chuck or for manual operation of the chuck alone. Operation of the spindle by non-specialists or unauthorized personnel is prohibited. Anyone involved in the installation, startup, maintenance, or operation of this product must have carefully read and understood this manual, in particular this section. We recommend that the user of this product have the relevant staff confirm in writing.

Areas of responsibility for spindle installation, startup, maintenance, and operation must be clearly defined and monitored to prevent safety incidents due to uncertainty. The machine manufacturer must take measures to identify and prevent overspeed whenever the spindle is in use, and inform the operator of the measures to be taken. Spindle units and associated electrical and mechanical protective devices and possibly high-voltage electrical systems must be in a safe condition at all times and must be inspected regularly, taking into account the effects of operation and the environment.

2. Safety instructions

Safe and reliable operation is only possible after the power supply, motorized spindle cooling, chuck fixture cooling, hydraulic system, pneumatic system, sensors and the motorized spindle control program have been installed safely and correctly; provided that the technical parameters and tolerances defined in the operating instructions are observed.

Please contact our technical department before operation if you have any questions. We cannot accept liability for damage to the motorized spindle due to faulty operation resulting from ignoring essential regulations and affecting the quality of machining.

◆ The motorized spindle is driven by dangerous high voltage and must be protected by a power-off connection when connected to the power supply of the machine. The housing of the motorized spindle must be earthed to protect against the risk of direct and indirect contact. The machine manufacturer is responsible for the safe operation of the overall equipment.

◆ Contact with the rotating parts of the motorized spindle can cause serious injury or death, as well as serious property damage and personal safety. The machine manufacturer is responsible for installing safety construction devices that can issue corresponding alarm signals.

◆ To protect against loose workpieces or chuck fixtures, baffles or protective covers must be installed to protect against flying parts. Protective devices must be installed, and their operation must be supervised by specialized staff (e.g., emergency stop switches).

3. Safe transport

Please check the shipping package immediately upon receipt for damage. When unpacking, please be careful and check the motorized spindle for external damage. If there is any damage, please notify the shipping company or contact us immediately. The following points should be noted during transportation or transshipment:

◆ Stepping on it while it is suspended is prohibited.

◆ Tilted lifting may cause it to slip off the rope, so ensure that it is transported horizontally.

◆ The unpacked or full box should be lifted vertically upwards and not allowed to tip over.

◆ Only lift the motorized spindle by the fiber rope around the motorized spindle housing or the eye bolt; never lift by the shaft.

◆ Improper or incorrect lifting may cause serious personal injury.

◆ The lifting equipment for transporting the spindle unit must have sufficient load-bearing capacity.

4. Safe assembly and repair

◆ Initial installation and repair of the motorized spindle must be carried out by professionals.

◆ High voltage is dangerous to life. Take safety precautions when connecting the socket.

◆ Take the following steps when connecting the power cord: ground the motorized spindle first when installing, and then connect the phase wire; do the opposite when disassembling the motorized spindle. (First remove the phase wire, and then the ground wire.)

◆ All aviation plugs and sockets must be inserted or disconnected correctly and completely.

◆ The motorized spindle must only be installed and operated in the specified position and with the specified protection.

◆ The motorized spindle must be connected according to the pipe diameter on the attached drawing.

◆ The motorized spindle may only be operated after it has been installed.

◆ The machine must be disconnected from the mains and secured against restarts before servicing. After

the work is finished, all safety equipment, such as baffles, must be installed.

- ◆ Cleaning must be carried out with care for all work.

5. Safety checks

- ◆ The electronic/mechanical equipment, high-voltage equipment of the machine must be kept in a safe condition and inspected regularly, taking into account operational and environmental influences.
- ◆ This is the responsibility of the equipment operator.

6. Safe operation

- ◆ The regulations for accident prevention must be observed.
- ◆ The motorized spindle may only be started after all prescribed safety equipment has been activated. Contact with the rotating spindle is prohibited (contact protection).
- ◆ The power supply must be disconnected before maintenance work is carried out; it must be ensured that it cannot be restarted. After maintenance work is finished, all safety equipment, such as baffles, must be installed.
- ◆ Only chuck fixtures that are suitable and have a maximum peripheral speed or rotational speed within the permissible range may be attached to the motorized spindle.
- ◆ Depending on the diameter of the chuck fixture, the higher the rotational speed, the greater the peripheral speed and the resulting centrifugal force. Therefore, the spindle must operate in a relatively enclosed workspace.
- ◆ When using large or extended chuck fixtures, care must be taken with their natural frequency to avoid damage to the spindle. If this happens, switch off immediately.

7. Storage

- ◆ The storage space must be dry, dust-free and clean, and as constant in temperature as possible (storage temperature 4°C to 45°C).
- ◆ The temperature of the spindle when it is put into storage should not exceed 45°C. To avoid condensation, the temperature should not drop below the dew point.
- ◆ The storage space for the motorized spindle should be kept still, without vibration or oscillation, to avoid Brinell indentation on the bearing raceway, which will affect the bearing life.
- ◆ The spindle should be powered on once every one to two months to ensure that it is running well.

8. Copyright

This manual is intended for reference by the machine manufacturer's technical staff, as well as staff responsible for installation, operation, maintenance and monitoring of the spindle, which includes technical specifications and drawings. Any reproduction or distribution of all or part of the contents is prohibited. The company owns the full copyright and the right to interpretation.

II. Introduction to Precision Lathe Motorized Spindle

1. Model description (Take BCES-A205FA-4011-2000/6000-A1B-A NC as the example)

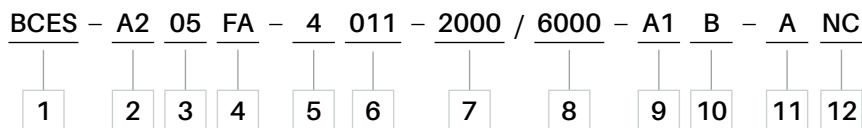

Model description table:

Code	Name	Description		Model Meaning
1	Product code	BCES: motorized spindle		CTB motorized spindle
2	Spindle end	A2: A2 end type		Type A2 connection to chuck
3	Spindle end specifications	04: No. 04 end specification 05: No. 05 end specification 06: No. 06 end specification	08: No. 8 end specification 11: No. 11 end specification 15: No. 15 end specification	No. 05 end specification
4	Structure form	FA: asynchronous air-cooled type FS: synchronous air-cooled type	WA: asynchronous liquid-cooled type WS: synchronous liquid-cooled type	Asynchronous air-cooled type
5	Voltage class	2: 200V	4: 400V	400V
6	Rated power	5P5: rated power 5.5Kw 7P5: rated power 7.5Kw 011: rated power 11Kw 015: rated power 15Kw	022: rated power 22Kw 030: rated power 30Kw 037: rated power 37Kw 045: rated power 45Kw	11kw
7	Rated speed	350: 350 rpm 500: 500 rpm 750: 750 rpm	2000: 2000 rpm 2500: 2500 rpm 3000: 3000 rpm	Rated speed: 2000r/min
8	Max. speed	000: 2000 rpm 4000: 4000 rpm 5000: 5000 rpm	6000: 6000 rpm 8000: 8000 rpm	Max. speed: 6000 r/min
9	Encoder	None: no encoder T4: 4-fold incremental encoder A1: sine-cosine encoder RA: Renishaw absolute encoder ER: Heidenhain sine-cosine encoder	RC: Chongyuan sine-cosine encoder LB: Lenord Bauer Mitsubishi protocol encoder RN: Heidenhain absolute rotary encoder SY: Syntec protocol encoder SAE: GUOCE TIME GRATING absolute encoder	Sine-cosine encoder
10	Brake	None: no brake	B: brake provided	B: brake provided
11	Smart card	None: no smart card	A: smart card provided	Smart card provided
12	Special signs	None: standard product (imported bearing brand) N: imported NSK bearing F: imported FAG bearing	S: Domestic CSC bearing C: Ceramic ball bearing (none, steel ball bearing) Others: Dedicated customer	NSK bearings Model number filled in from top to bottom in order

2. Product description

2.1 Motor unit

The motorized spindle is driven by a built-in three-phase motor. The motor consists of a rotor and a stator, with the rotor directly mounted on the spindle. The motor is specially designed to meet the requirements of machining applications, featuring high power density and torque. The motor winding is sealed with adhesive to ensure many years of reliable winding insulation. A thermal protector is placed at the end of the winding to prevent damage to the winding in the event of overload or abnormal conditions.

2.2 Spindle specifications

Spindle model	Front bearing	Rear bearing	Through-hole	Chuck interface	Fitting chuck	Fitting cylinder	Diameter x Overall length	Weight
A204WS	7014	NN3012	46	A2-4	3H-05A4	TK533	Φ180x495	66
A205WSA	NN3018	NN3015	56	A2-5	3H-06A5	F1246S	Φ200x590	180
	90BAR10S							
A205WS	7018	NN3015	56	A2-5	3H-06A5	TK646A	Φ200x550	100
A206WS	NN3022	NN3018	67	A2-6	3H-08A6	F1552S	Φ240x690	175
	110BAR10S							
A208WA	NN3024	NN3020	80	A2-8	3H-10A8	TH-1075	Φ445x720	634
	120BAR10S							
A208WS	NN3024	NN3022	87	A2-8	3H-10A8	TH-1075	Φ320x672	265
	120BAR10S							
A211WD	NN3032	NN3024	80	A2-11	3H-15A11	TH-1512	Φ445x780	680
	160BAR10S							
A215W	NN3032	NN3024	80	A2-15	3V-24A15	RK-200	Φ630x645	1100
	160BAR10S							

Spindle model	Rated power	Rated torque	Rated speed	Max. speed	Rated current	Rated voltage	Number of poles	Moment of inertia
A204WS	5.5	17.5	3000	6000	21/10.5	200/380	8	0.028
A205WSA	15	72	2000	6000	29	380	8	0.179
A205WS	11	42	2500	5000	42/21	200/380	8	0.081
A206WS	22	105	2000	4000	84.5/48	200/380	8	0.194
A208WA	30	570	500	4000	56	380	8	0.982
A208WS	37	283	1250	3000	83.4	380	8	0.423
A211WD	22	600	350	2000	73.2	240	8	1.71
A215W	45	1230	350	2400	91.4/86	380	8	6.84

2.3 Encoder

The encoder is located at the rear of the spindle and consists of a high-precision gear (or grating wheel hub) and a sensor head. It is used to detect the angular position of the rotating shaft and is used to control the speed and stop of the spindle at any angular position. Our company can install different encoders according to various numerical control systems and drivers (such as Siemens, Fanuc, Mitsubishi, etc.).

Motorized spindle specifications	Number of signal cycles	Positioning accuracy (")	Repeatability (")	Scanning head waveform or communication protocol			
				CTB driver	Siemens driver	Fanuc driver	Mitsubishi driver
A204WS	200	150	15	CTB 协议	1Vpp Endat	1Vpp	Mitsubishi protocol
A205WS	256/2048	80/20	15/5				
A205WSA	256/2400	80/20	15/5				
A206WS	375/2800	80/15	15/5				
A208WA	375/2800	60/15	15/5				
A208WS	375/2800	60/15	15/5				
A211WD	384/2800	60/15	15/5				
A215WA	375/2800	60/15	15/5				

2.4 Motor cooling system

The stator of the motor generates driving power and has a high power density. It generates a lot of heat during spindle operation, which is the main source of heat for the spindle. This spindle is designed with a cooling water channel that circulates around the stator, so an external supporting circulating water cooling (or oil cooling) system is required. This cooling system provides a low-temperature coolant that passes through the water channel to take away most of the heat generated by the stator and release it into the air, thereby ensuring that the motor stator will not overheat and be damaged.

Our company recommends a thermostatic cooling system. When using a water cooling medium, the cooling capacity of the selected cooling system should be greater than 10% of the power of the selected motorized spindle; when using an oil cooling medium, the cooling capacity of the selected cooling system should be greater than 15%-20% of the power of the selected motorized spindle. When using a water cooling medium, distilled water should be used; and an anti-rust agent should be added to prevent internal rust from clogging the cooling pipes.

2.5 Motor thermal protection system

The A2 series of motorized spindles for turning has a built-in temperature sensor, which is either switch-type or resistance-type.

The temperature protection switch has an operating temperature of 115°C, with temperature protection resistors KTY84-130, PT3C-51F, PT100, etc. optional.

Note: If there are no special requirements, the default temperature protection resistor for the spindle is KTY84-130.

KTY84-130 Temperature and Resistance Table

Temperature (°C)	Resistance (Ω)		
	MIN	TYP	MAX
-40	340	359	379
-30	370	391	411
-20	403	424	446
-10	437	460	483
0	474	498	522
10	514	538	563
20	555	581	607
25	577	603	629
30	599	626	652
40	645	672	700
50	694	722	750
60	744	773	801
70	797	826	855
80	852	882	912
90	910	940	970
100	970	1000	1030
110	1029	1062	1096
120	1089	1127	1164
130	1152	1194	1235
140	1216	1262	1309
150	1282	1334	1385
160	1350	1407	1463
170	1420	1482	1544
180	1492	1560	1628

PT3C-51F Temperature and Resistance Table

Temperature (°C)	Resistance (Ω)		
	MIN	TYP	MAX
-40	1398.0095	1536.8903	1688.8295
-30	752.5456	822.1456	897.8232
-20	422.4834	458.8736	498.1986
-10	246.2212	265.9746	287.1979
0	148.3746	159.4603	171.3057
10	92.5115	98.5459	105.3580
20	58.7865	62.5906	66.6142
25	47.3978	50.3553	53.4760
30	38.4395	40.7517	43.1857
40	25.7022	27.1377	28.6419
50	17.5392	18.4474	19.3949
60	12.1942	12.7786	13.3857
70	8.6246	9.0064	9.4031
80	6.1970	6.4498	6.7102
90	4.5183	4.6876	4.8613
100	3.3392	3.4537	3.5708
110	3.3392	3.4537	2.6567
120	1.8923	1.9460	2.0004
130	1.4486	1.4857	1.5232
140	1.1204	1.1461	1.1720
150	0.8749	0.8928	0.9107
160	0.6861	0.7018	0.7176
170	0.5428	0.5565	0.5703
180	0.4329	0.4448	0.4569

2.6 Bearings and lubrication

The spindle's rotating shaft (and other rotating parts) is supported by high-precision bearings. This provides excellent accuracy and the loading capacity at high speeds. The precisely calculated bearing assembly can carry the combined axial and radial forces during processing without any backlash. The thermal load generated on the rotating shaft will not impact the mechanical strain. Our turning motorized spindles are all rigidly preloaded, grease-lubricated, and maintenance-free for life.

2.7 Standard for accuracy test

According to JB/T 10801.3-2007, which specifies requirements for the design, manufacture and acceptance of motorized spindles, the following table summarizes the general inspection items:

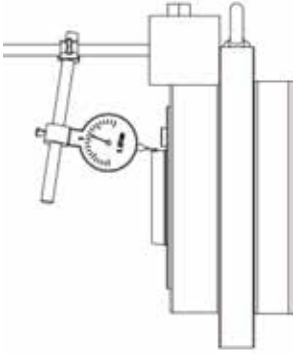
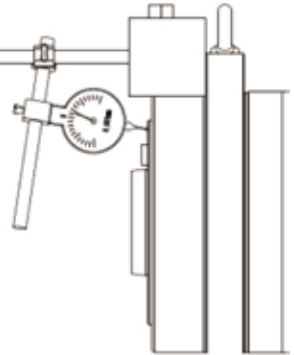
No.	Simplified diagram	Inspection items	Our standards (mm)	
1		Radial runout	A204WS	0.003mm
			A205WS	0.003mm
			A205WSA	0.003mm
			A206WS	0.004mm
			A208WS	0.004mm
			A211WD	0.005mm
			A215WA	0.005mm
2		End face runout	A204WS	0.003mm
			A205WS	0.003mm
			A205WSA	0.003mm
			A206WS	0.004mm
			A208WS	0.004mm
			A211WD	0.005mm
			A215WA	0.005mm

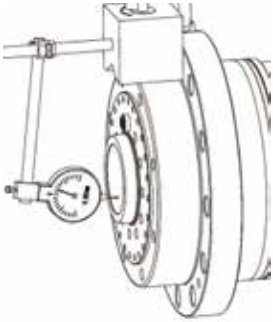
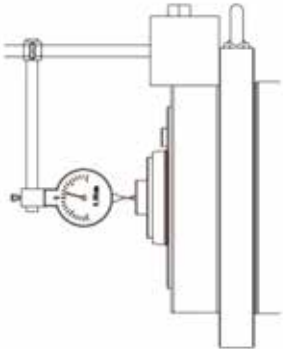
No.	Simplified diagram	Inspection items	Our standards (mm)	
3		Internal taper (hole) runout	A204WS	0.003mm
			A205WS	0.003mm
			A205WSA	0.003mm
			A206WS	0.004mm
			A208WS	0.004mm
			A211WD	0.005mm
			A215WA	0.005mm
4		Axial runout	A204WS	0.003mm
			A205WS	0.003mm
			A205WSA	0.003mm
			A206WS	0.003mm
			A208WS	0.003mm
			A211WD	0.005mm
			A215WA	0.005mm

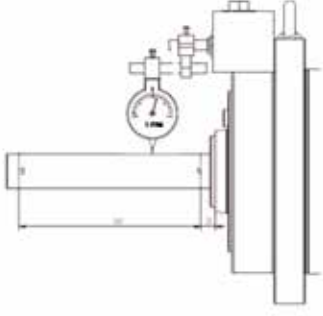
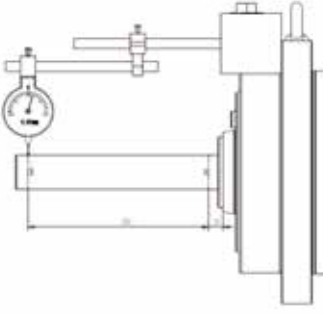
No.	Simplified diagram	Inspection items	Our standards (mm)	
5		Proximal runout of check bar	A204WS	0.003mm
			A205WS	0.003mm
			A205WSA	0.003mm
			A206WS	0.003mm
			A208WS	0.003mm
			A211WD	0.005mm
6		Distal runout of check bar	A204WS	0.01mm
			A205WS	0.01mm
			A205WSA	0.01mm
			A206WS	0.01mm
			A208WS	0.012mm
			A211WD	0.012mm
			A215WA	0.012mm

2.8 Cheek bar production

The structure of the check bar is shown in Figure 1.

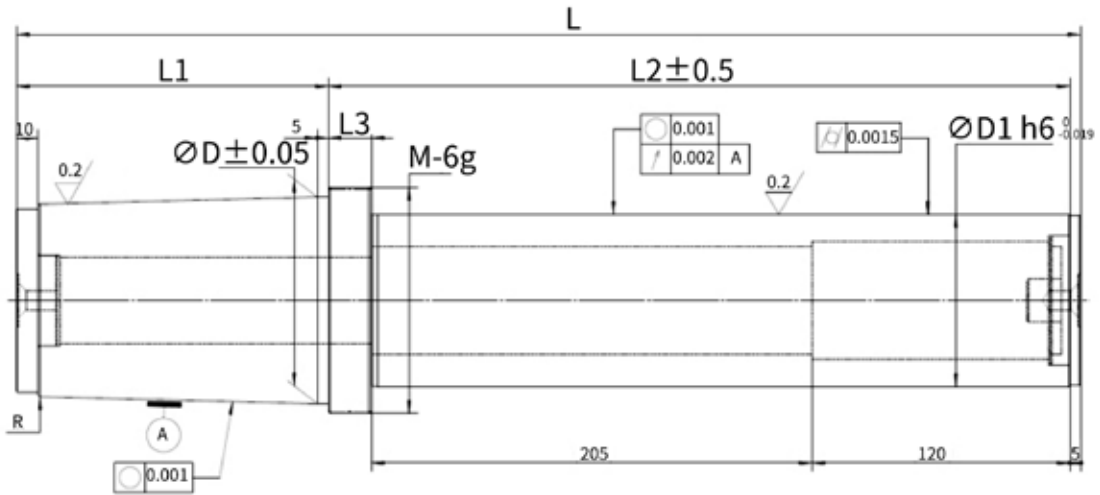

Figure 1

Table of Dimensions:

Model of motorized spindle	Taper ratio	ϕD	$\phi D1$	M	L	L1	L2	L3
A204WS/FS	1:20	49	30	M55x1.5	425	75	345	20
A205WS	1:19.18	63.348	35	M66x1.5	465	115	345	20
A206WS	1:20	80	40	M84x1.5	525	175	345	20
A208WS	1:20	96	80	M105x2.0	495	145	345	20
A208WA	1:20	90	75	M100x2.0	495	145	345	20
A211WA	1:20	90	75	M100x2.0	495	145	345	20
A215W	1:20	90	75	M100x2.0	495	145	345	20

Note: The check bars A2-4, A2-5 and A2-6 can be made with a solid core, while the rest should be hollowed out to reduce weight.

III. Use of the Lathe Motorized Spindle

1. Spindle installation

The accuracy, lifespan and performance of the spindle are directly affected by whether it is installed properly. Therefore, it is recommended that the design department and mounting department fully investigate the spindle installation and complete the installation according to the operating standards. The operating standards are as follows:

1.1 Cleaning the spindle and related parts

It is recommended that the spindle be unsealed just before installation. Use a crane or hoist with sufficient load-lifting capacity to transport the spindle, and lift the motorized spindle by the fiber rope wound around the motorized spindle housing or the eyebolt. Place a wooden or soft frame on a flat workbench or floor, as shown in Figure 2. To protect the spindle from dust and corrosion during transportation and storage, it is shipped with anti-rust oil applied to the surface. Normally, it is sufficient to wipe the surface with a cloth dampened in technical alcohol. If you spray cleaning fluid onto the spindle, make sure that it is positioned so that the drain hole is facing downwards and that all surfaces, holes and pipes are cleaned to ensure that no residue remains. The spindle box and associated parts also need to be cleaned in the same way.

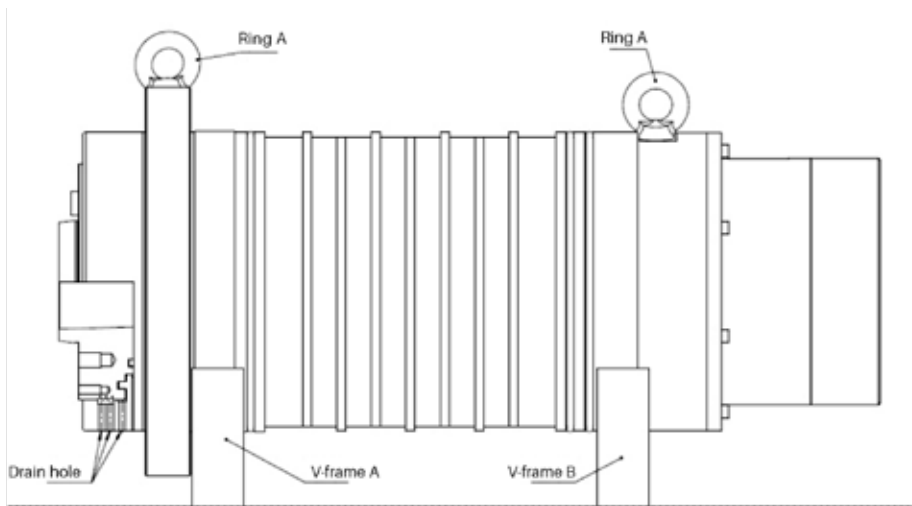

Figure 2

1.2 Checking the accuracy of the spindle and related parts

This inspection standard is based on relevant information such as national standards and superior industry standards, and is only applicable to the factory inspection of Lathe Motorized Spindles produced by our company. For specific values, see P7 “2.7 Standards for accuracy test” .

1.2.1 Spindle accuracy test

Tools: dial gauge, check bar

Test method: see the diagram in “2.7 Standards for accuracy test” on P7

Test standards: see the data in “2.7 Standard for accuracy test” on P7

1.2.2 Spindle dimensions test

Tools: external micrometer

Test method: use an external micrometer for measurement

The external diameter at the position shown in Figure 10

Test standards: comply with the requirements of the drawing (Note: the external diameter dimensions of the returned drawing shall prevail when signing. The following table only provides some of the external diameter dimensions of the motorized spindle)

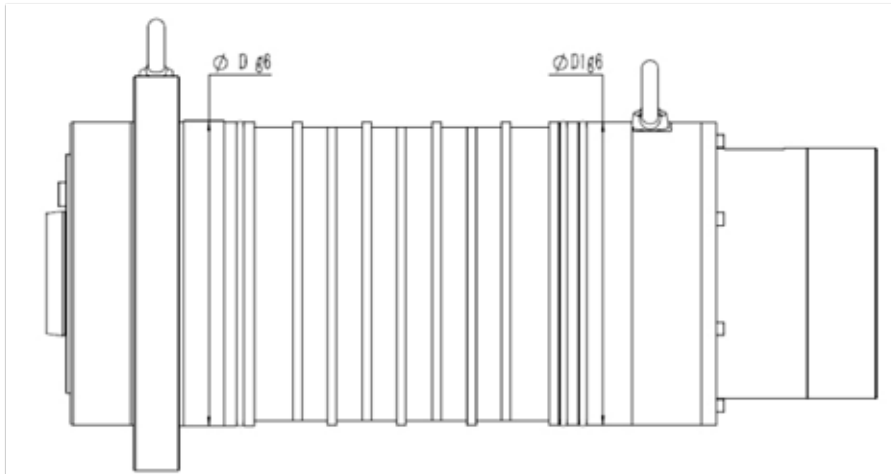

Figure 3

Reference table for external dimensions of the motorized spindle:

Motorized spindle model	External diameter D (mm)	External diameter D1 (mm)
A204WS	Φ181 (-0.015 / -0.044)	Φ180 (-0.014 / -0.039)
A205WS	Φ201 (-0.015 / -0.044)	Φ200 (-0.015 / -0.044)
A205WSA	Φ201 (-0.015 / -0.044)	Φ200 (-0.015 / -0.044)
A206WS	Φ241 (-0.015 / -0.044)	Φ240 (-0.015 / -0.044)
A208WA	Φ446 (-0.022 / -0.066)	Φ445 (-0.022 / -0.066)
A208WS	Φ321 (-0.018 / -0.054)	Φ320 (-0.018 / -0.054)
A211WD	Φ446 (-0.022 / -0.066)	Φ445 (-0.022 / -0.066)
A215W	Φ635 (-0.024 / -0.074)	Φ630 (-0.022 / -0.066)

1.2.3 Visual inspection

Tools: Visual inspection

Test method: Check the appearance of the motorized spindle, nameplate signs, mounting structure, fasteners, accessories, etc.

Test standards: The product appearance is clean, without rust or dents; the product signs are correct and complete, meeting product requirements.

1.2.4 Overall insulation resistance test

Tools: insulation resistance meter

Test method: connect one end of the insulation resistance meter to the power cord UVW and the other end to the housing; rotate the rocker of the insulation resistance meter at a speed of 120 rpm/min for 30 seconds and then read the resistance value.

Test standards: $\geq 500M\Omega$

Precautions: The connection must be secure with a steady rotation speed; the duration must be such that the meter pointer stabilizes before it is read.

1.2.5 Box size test

Tools: three-coordinate measuring device

Test method: measure with three coordinates

The external diameter dimensions and geometric tolerance at the positions shown in Figure 4

Test standards: comply with the requirements of the drawing (Note: the external diameter dimensions of the returned drawing shall prevail when signing.)

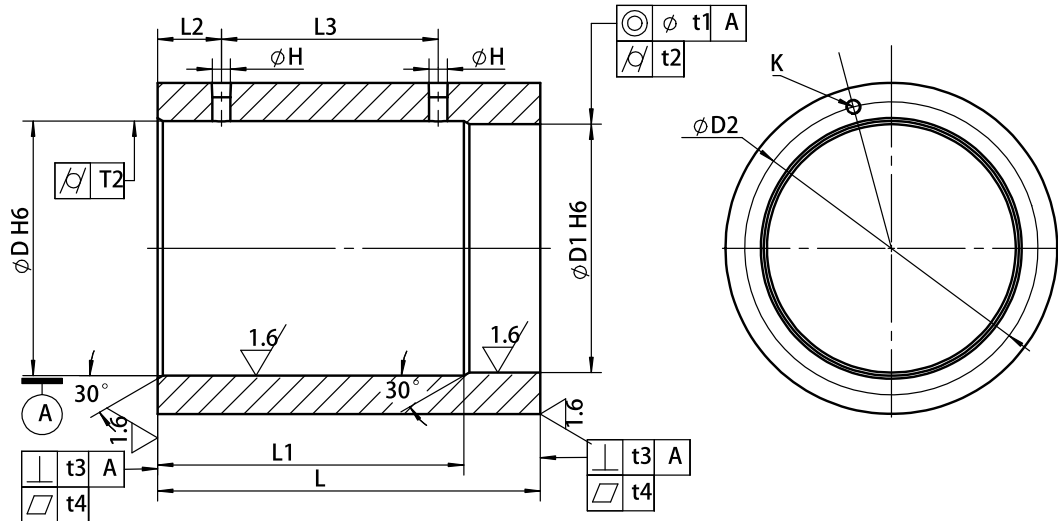

Figure 4

Reference table for the dimensions of the spindle box:

Motorized spindle model	ΦD	$\Phi D1$	$\Phi D2$	L	L1	L2	L3	t1	t2	t3	t4	K	H
A204WS	181	180	200	250	225	55	165	0.01	0.005	0.01	0.005	M10	6
A205WS	201	200	230	280	240	63	169	0.01	0.005	0.01	0.005	M10	7
A205WSA	201	200	230	341	295	63	225	0.01	0.005	0.01	0.005	M10	7
A206WS	241	240	270	409	355	70	278	0.01	0.005	0.01	0.005	M12	10
A208WS	321	320	350	380	335	70	255	0.015	0.008	0.015	0.008	M12	12
A208WA	446	445	480	445	371	51	299	0.015	0.008	0.015	0.008	M12	12
A211WD	446	445	480	545	487	80	396	0.02	0.01	0.02	0.01	M16	16
A215W	635	630	680	458	373	93	270	0.02	0.01	0.02	0.01	M16	16

1.3 Spindle installation

Spindles and related parts that have passed all the accuracy tests in 1.2 are assembled in the following steps:

1.3.1 Assembly of spindle seal

Prior to installing the spindle in the box, please check that the outer diameter of the spindle seal groove is fitted with an O-ring of the correct specification and that the surface of the seal ring is not damaged. Make sure that the hole in the box is guided, otherwise the ring will be easily cut during assembly.

1.3.2

Apply a thin layer of grease evenly to the contact surfaces during installation, and apply a little more to the O-ring area.

1.3.3 Installation

Prior to installing the motorized spindle, check whether the holes in the box have guides and whether the cooling channels and process holes have burrs. If any abnormalities are found, repair them in time, otherwise it is easy to cause ring cutting during assembly.

The motorized spindle can be installed horizontally or vertically in the box, as shown in the figure.

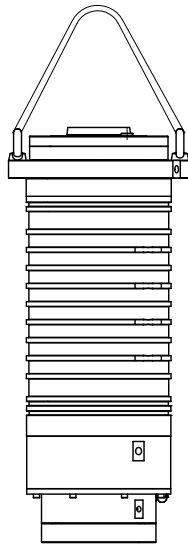

Vertical assembly

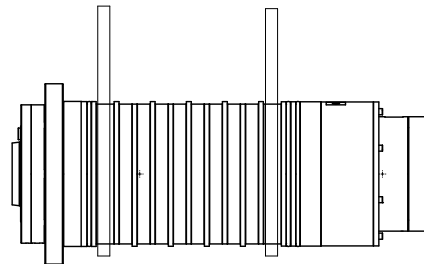

Horizontal assembly

The motorized spindles for turning are divided into horizontal turning spindles and vertical turning motorized spindles according to the different operating conditions of customer applications. The two spindles cannot be used interchangeably. Please check the spindle model and check the drawings carefully before assembly.

If the spindle is installed horizontally, make sure that the drain hole is positioned downward during spindle assembly, as shown in the figure. Cutting fluid that enters the spindle labyrinth during processing will be discharged through this hole, preventing cutting fluid from entering the interior of the spindle and damaging the bearings.

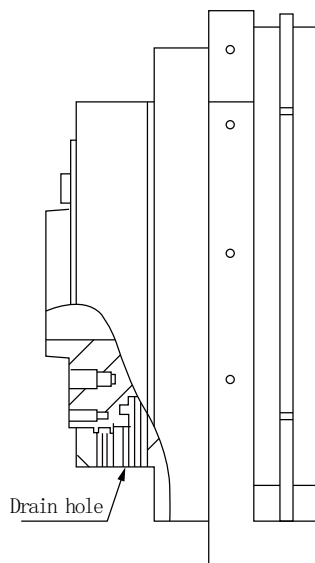

Figure 5

If the spindle is installed vertically, the box design should take into account that the accumulation of chips and cutting fluid in the bed during the machining process does not exceed the spindle flange surface, so as to avoid entering the interior of the spindle through the mechanical labyrinth and resulting in bearing damage. The bottom of the box should be designed with guide holes to prevent damage to the spindle due to liquid accumulation inside the box.

1.4 Electrical connection

The motorized spindle and the drive are connected via a special cable. The power cable is marked with plugs labeled UVW and is connected to the respective sockets on the spindle end. The ground wire is fastened to the ground wire symbol on the spindle end with a special screw. The encoder cable is also connected to the socket on the spindle end via a special plug, as shown in the figure:

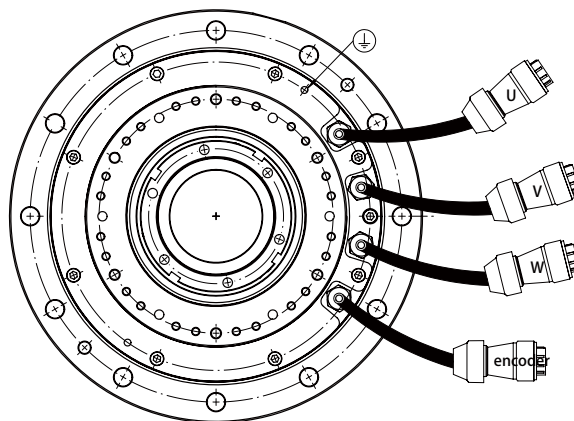

Figure 6

Spindle-end 12-core socket model: WY20J12TE

The 1VPP protocol is defined as follows:

Pin	Signal	Color	Remarks
1	Z-	Brown and white	Encoder signal Z inverted
2	A-	Green and white	Encoder signal A inverted
3	Z+	Brown	Encoder signal Z
4	A+	Green	Encoder signal A
5	KTY84+	Grey	Motor thermal protection temperature resistor
6	KTY84-	Grey and white	Motor thermal protection temperature resistor
7	B-	Blue and white	Encoder signal B inverted
8	0V	Red and white	Power supply 0V
9	B+	Blue	Encoder signal B
10	+5V	Red	Mains voltage
11	KTY84+	Black	Motor thermal protection temperature resistor (backup)
12	KTY84-	Black and white	Motor thermal protection temperature resistor (backup)

The Syntec encoder protocol is defined as follows:

Pin	Signal	Color	Remarks
2	D-	White	Inverse data
4	D+	Brown	Normal data
8	0V	Blue	Power 0V
10	+5V	Red	Power 5V

The Mitsubishi protocol is defined as follows:

Pin	Signal	Color	Remarks
2	Date-	Gray	Inverse data
4	Date+	Gray	Normal data
5	KTY84+	Blue	Motor thermal protection temperature sensor
6	KTY84-	Blue and white	Motor thermal protection temperature sensor
7	RQ-	Brown and white	Inverse request signal
8	0V	Black and white	Power 0V
9	RQ+	Brown	Normal request signal
10	+5V	Red	Power 5V

2. Motorized spindle trial run

Check again before the first run that all connections are correct and that the control system of the motorized spindle is working properly. Also check the following:

2.1 Pre-operation check

Fluid cooling	Free cooling circuit
	Free motorized spindle
	Circulating pump in operation
	Enough flow
Air cooling	Fan working
	Wind blowing upwards
Hydraulic	Hydraulic system ready

2.2 Operation

The first run is performed without chuck fixture and cylinder. If the motorized spindle has been standing for a long time at room temperature or below, it cannot run at maximum speed immediately after starting in order to protect the spindle bearings. For a motorized spindle that is being used for the first time or has been standing for more than one month, the following procedure should be followed before startup:

Step	Rotation	Runtime (s)	Stop time (s)	Cycles
1	50% of max. speed	20	120	5
2	75% of max. speed	20	120	5
3	Max. speed	20	120	5
4	Max. speed	30	120	10
5	Max. speed	60	120	10

When restarting the machine after the spindle has been stopped for more than 8 hours, it is recommended to follow the procedure below to ensure the accuracy of the spindle and sufficient lubrication of the bearing grease:

Step	Rotation	Runtime (min)
1	10% of max. speed	5
2	20% of max. speed	5
3	50% of max. speed	5
4	Max. speed	15

Note: If the max. spindle speed is not used, the max. speed will be set to the operating speed. During the running-in period, the bearing temperature should be monitored. If the temperature exceeds 60°C, the machine should be stopped until the temperature drops. If the spindle temperature remains unbalanced or there are abnormal noises after multiple running-in cycles, please contact our company for troubleshooting.

2.3 Operation check

The motorized spindle needs to be calibrated after operating in 2.2 as follows:

(1) Accuracy review test

Tools: dial indicator, check bar

Test method: Follow the requirements of the P7 2.7 accuracy test standard diagram to review

Test standards: Follow the data of the P7 2.7 Standards for accuracy test

(2) Noise test

Tools: Noise measuring instrument

Test method: Measure the noise of the motorized spindle at different speeds in front to back and side to side at the same level, 1.0 m from the spindle in three directions. Take the maximum value as the measured value.

Test standards: $\leq 75\text{dB}$

(3) Vibration test

Tools: Vibration meter

Test method: Measure vibration at different speeds with the motorized spindle without the chuck cylinder.

Test standards: $\leq 0.8\text{mm/s}$

(4) Temperature rise test

Tools: Multi-channel temperature itinerant detecting instrument

Test method: The temperature of the front cover, body and rear cover of the motorized spindle is tested after it has reached a constant temperature at maximum speed (or after the chuck cylinder is installed and continuous S1 operation is performed) (the cooling equipment must be operating normally).

Test standards: $\leq 30\text{K}$

Note: The constant temperature ($^{\circ}\text{C}$) \leq ambient temperature ($^{\circ}\text{C}$) + 30°C

(5) Positioning accuracy test

Tools: Laser interferometer

Test method: Use a laser interferometer to measure the positioning accuracy, repetitive positioning accuracy, and backlash of the motorized spindle

Test standards: Follow the standard data in the P05 2.3 Encoder Diagram

3. Installation and application of accessories

3.1 Connecting the chuck cylinder

After the motorized spindle has passed the trial run and tests, the chuck, fixture, rotary cylinder, and hydraulics are installed for use. An overview of the overall installation of the chuck, rotary cylinder, and hydraulic station is shown in Figure 7.

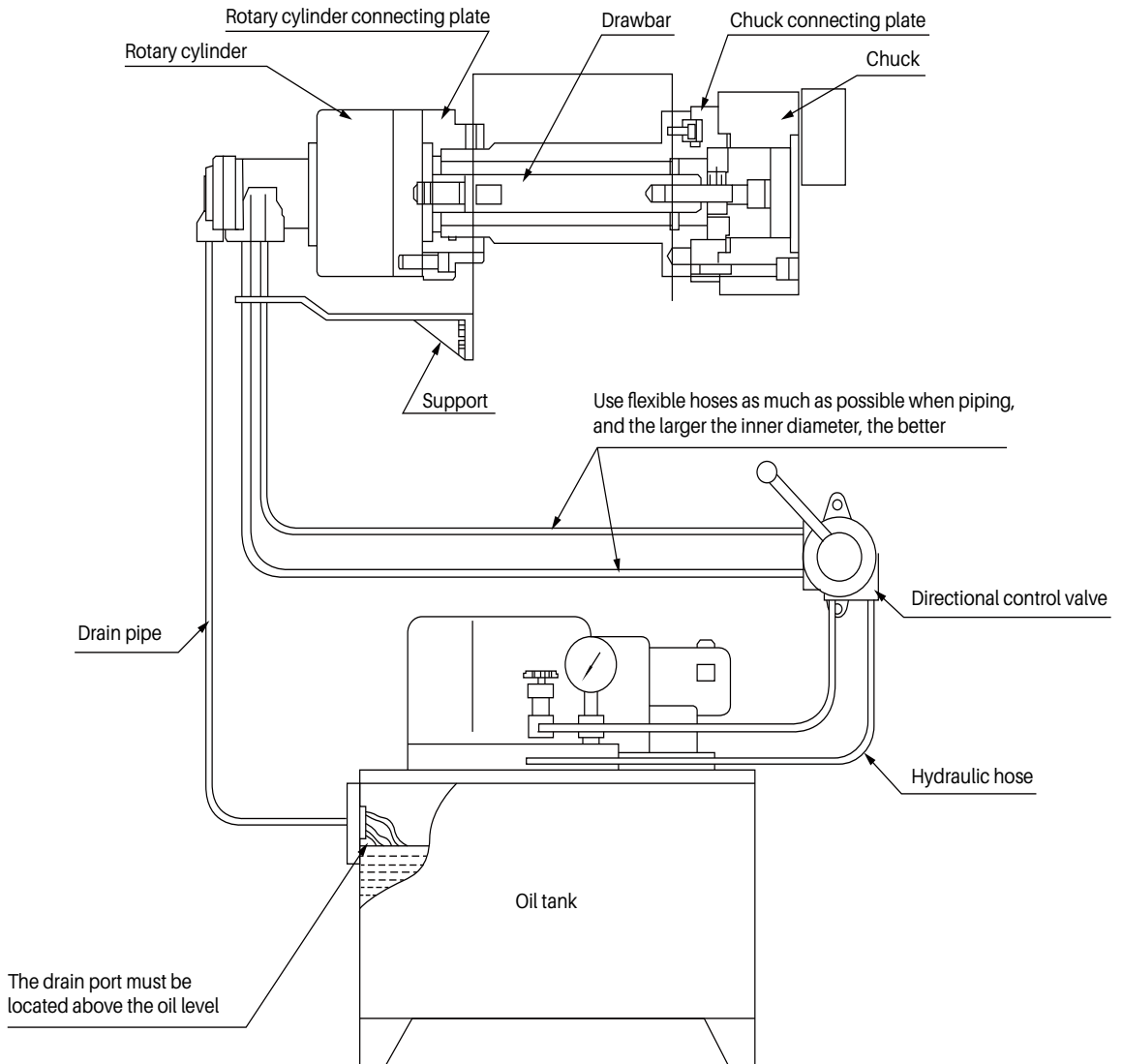

Figure 7

The specific steps are as follows:

(1) First, when installing the drawbar in the rotary cylinder, retract the piston to the bottom as far as possible and tighten it in place (if the piston is in the middle of its stroke and the drawbar is tightened, the piston's check pin may be damaged);

(2) Install the rotary cylinder with the drawbar on the connecting flange of the motorized spindle rotary cylinder as shown in Figure 16; screw in the hexagonal socket head cap screw 1 and rotate the spindle by hand to ensure that the cylinder has a front runout ≤ 0.015 mm and a rear runout ≤ 0.030 mm;

(3) After checking that the hydraulic piping has been assembled correctly, set the oil pressure to a low state (0.4-0.5 MPa); run the piston back and forth 2-3 times, then stop it at the front end (with the drawbar extended), and then turn off the power supply;

(4) Remove the soft jaws and protective cover from the chuck, and lift the chuck to the front end of the motorized spindle using a lifting belt. Insert the handle into the center hole of the chuck and rotate the socket head cap screw 2 to screw it into the drawbar. If the locking is not very smooth during this process, recheck whether the screw pitch is correct and whether the center is tilted. Forcibly locking it in with excessive force may cause damage and poor accuracy.

Align the end key on the spindle with the positioning groove on the chuck, and rotate the handle to connect the socket head cap screw 2 with the drawbar in place. The chuck and the end of the spindle should be close to fitting, and then tighten the socket head cap screws 3 in sequence. The force on each screw should be even to ensure that the chuck round runout is ≤ 0.010 mm. Then install the chuck protective cover and soft jaws. Installation may vary between manufacturers and models. The specific installation situation is subject to the requirements of the operating instructions supplied with the chuck and rotary cylinder used.

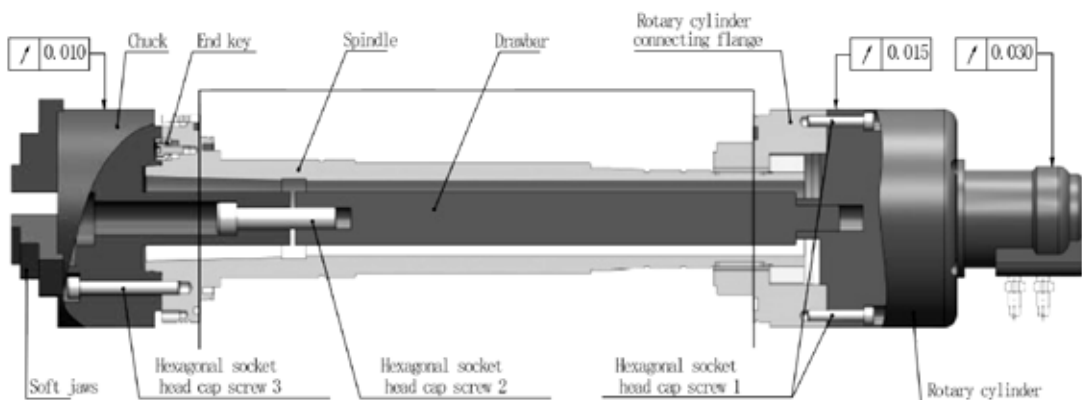

Figure 8

(6) To prevent the oil cylinder housing from rotating, a support is installed at the protrusion at the bottom of the oil port. The support is fixed to the body and ensures a gap of 3-5 mm with the oil pipe, as shown in Figure 9.

(7) Before installing the oil pipe, any foreign matter inside the pipe must be completely cleaned. The drain pipe and oil pipe must not form a back pressure state, and flexible hoses must be used for the pipes to prevent the bending and tension from affecting the action of the hydraulic cylinder.

(8) The designer of the hydraulic circuit provides a safety circuit based on the principles of ease of operation and safety to prevent hazards during power outages.

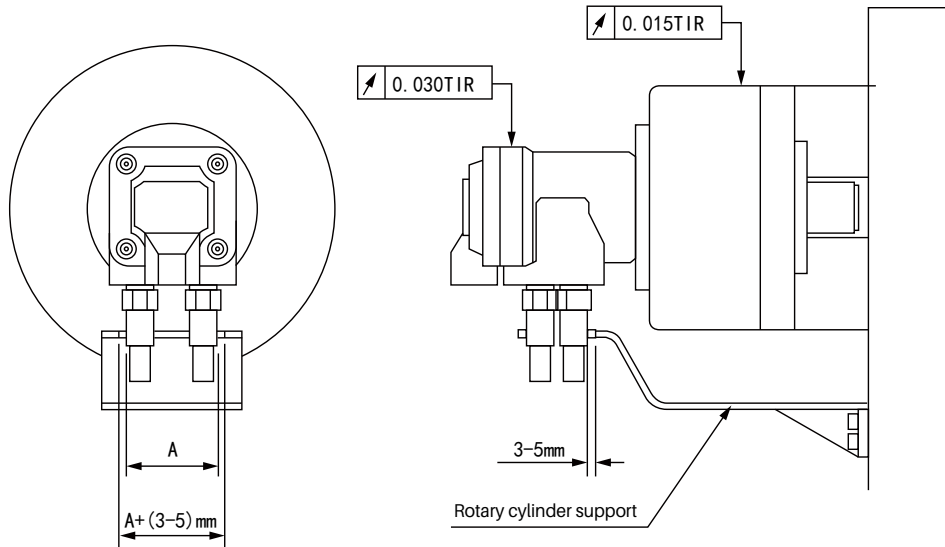

Figure 9

3.2 Cooling the motorized spindle

The spindle is in liquid cooling mode, as shown in Figure 10. When the motorized spindle is installed in the customer's spindle box, the motorized spindle and the outer housing form a cooling circuit. The coolant inlet and outlet are connected by the customer. Please note that if the coolant outlet connector is on the top when installed vertically, it will prevent air from accumulating in the cooling circuit, which will result in insufficient cooling of the spindle. At the same time, the following points must be met:

- (1) The set temperature of the cooling system is recommended to be 28°C-32°C;
- (2) The cooling system flow rate: A204WS, A205WSA, and A206WS require a cooling flow rate of 8-12L/min, while A208WA, A208WS, A211WD, and A211WA require a cooling flow rate of 12-20L/min;
- (3) The cooling capacity of a water-cooled machine is greater than 10% of the rated power of the spindle, and the cooling capacity of an oil-cooled machine is greater than 15% of the rated power.
- (4) When a water-cooled machine is selected, use distilled water as the cooling medium and add glycol antifreeze or anti-rust agent (e.g., Fenox protective agent F11: 200). When an oil-cooled machine is selected, it is recommended to use 10# heat transfer oil.

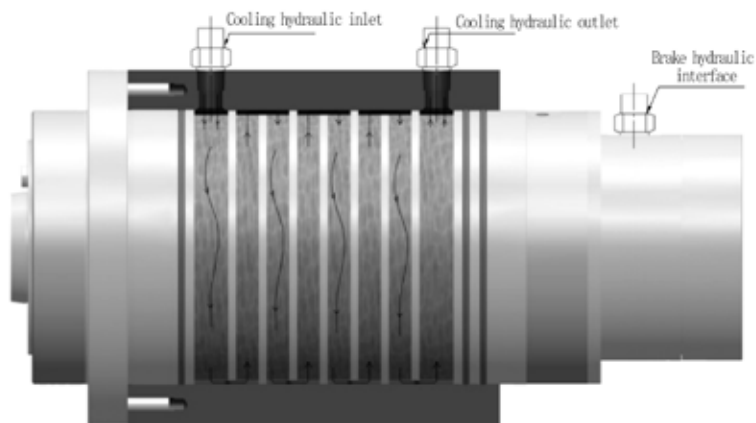

Figure 10

3.3 Spindle lock

Refer to the spindle outline drawing to lock the position of the interface and connect the hydraulic pipe. The pressure requirement is 5 ± 0.5 Mpa, which can be adjusted within a certain range after confirming with the technician according to actual needs. It should be noted that the hydraulic pipe should not be too long and a hose should be used for connection.

Spindle locking control logic:

Spindle positioning: Spindle rotates to specified angle → lock pressure inlet to apply pressure → driver disable

Spindle rotation: Driver enables spindle → lock pressure inlet to release pressure (pressure is 0) → spindle rotates

Note: If the driver has a current-limiting function, it is not necessary to disable the driver. There is a difference in the locking control between a direct-drive spindle and a transmission spindle with a synchronous belt. After the direct-drive spindle is positioned loosely, if the current is not limited or the driver is disabled, the current will continue to rise, which is very likely to cause the spindle to burn out. The spindle locking torque is as follows:

Spindle model	Pressure (Mpa)	Locking torque (N.m)
A204WS	5 ± 0.5	35
A205WA	5 ± 0.5	150
A205WS	5 ± 0.5	90
A206WS	5 ± 0.5	210
A208WA	5 ± 0.5	1150
A208WS	5 ± 0.5	560
A211WD	5 ± 0.5	1200
A215W	5 ± 0.5	2500

3.4 Critical Operating Statement

After installation and testing of the above items, the motorized spindle can be used officially and can be used in different processing conditions according to different parameters. In order to ensure trouble-free operation with low maintenance of the motorized spindle, the following rules must be observed:

During processing, care must be taken that the front end of the spindle is not submerged and that the drain holes are not blocked or otherwise prevented from draining properly. Coolant can enter the front end of the bearing or inside the spindle, which will significantly reduce its service life.

After replacing the chuck fixture, the spindle must be started after the chuck fixture cylinder has been replaced and tightened into place.

The specifications in the dimensional drawings must be observed.

Maintenance on the motorized spindle may only be carried out by a qualified professional.

Maintenance must be carried out with the power supply disconnected and prevented from being switched on again. After maintenance has been completed, the baffles must be installed as specified.

All work must be carried out with absolute cleanliness.

If liquid leaks occur during operation, the machine must be stopped for inspection to avoid possible damage.

Worn or defective spindles can be returned to us for proper disposal or recycling by the manufacturer.

IV. Troubleshooting

Troubleshooting list

Failure	Possible causes	Resolution
The spindle cannot start.	Phases are incorrectly connected.	Check the electrical connection
Spindle heating	The coolant system fails to work	If the cooling system does not start, check whether the switch is on, whether the cooling system indicates a fault code, and eliminate the fault code as required by the cooling system; If the coolant system pipe is blocked, clear the dirt from the pipe and replace the cooling medium in time; If the cooling pipe is crushed, restore the pipe as it was or replace it;
	The coolant temperature is too high	The cooling capacity of the cooling system does not meet the cooling capacity requirements of the spindle
	An overload occurs	Check whether the load exceeds the rated torque of the spindle
	Worn bearings	Return to replace the bearings
Spindle noise	Bearing noise	Remove accessories connected to the spindle by a third party; after the spindle has reached its max speed, disable it and let it slowly stop with the inertia of the spindle itself; if the fault persists, it needs to be returned to the factory for repair.
	Electromagnetic noise	Remove accessories connected to the spindle by a third party; after the spindle has reached its max speed, disable it and let it slowly stop with the inertia of the spindle itself; if the fault disappears, check whether the driver parameters are correct.
	Vibration noise	Remove the accessories connected to the spindle by a third party, and run the spindle. If the vibration noise disappears, check whether the nearby assemblies such as the chuck, drawbar, and rotary cylinder are coaxial.
Insufficient spindle locking force	Locking oil pressure below the specified value	Check the hydraulic unit and provide pressure as required by the spindle
High resistance to spindle rotation	Locking pressure inlet fails to relieve	Check the hydraulic unit for pressure relief
Large spindle positioning error	Positioning processing logic error	Refer to the control logic in this manual for required modifications
	Driver parameter issues	Recheck and optimize the driver parameters

Dealer

CTB超同步

CTB Co., Ltd.

Address: No. 9, 6th Yunxi Road, Miyun Economic Development Zone, Beijing (101500)

Tel: 010-69076533

Fax: 010-69076577

Hotline (24h): 400-888-9055

File No.: CTB-PI-I-2603-01-01

The information on this product is subject to change without notice as improvements are made.